

## INSTRUCTION MANUAL – AIR DRIVEN HYDRAULIC PUMPS:

**Model Series: AHP1120, AHP1120R, AHP1121, AHP1121R, AHP1122, AHP1122R, AHP1141, AHP1142, HAP21011, HAP21012, HAP21014, HAP21016, HAP21021, HAP21022, HAP21024, HAP21026, HAP21031, HAP21032, HAP21034, HAP21036, HAP21041, HAP21042, HAP21044, HAP21046,**



**NOTE:** Spare parts sheets for these products are available from the Hi-Force website at:

[www.hi-force.com](http://www.hi-force.com)

or from your local regional Hi-Force Sales office or authorized local Hi-Force distributor.

### 1.0 Inspection of the product upon receipt:

On receipt of the product, visually inspect the item for any evidence of shipping damage. Please note shipping damage is not covered by warranty. If shipping damage is found notify the carrier immediately and refrain from putting the product into service. The carrier is responsible for repair and replacement costs resulting from damage in transit shipment.

### 2.0 Safety Precautions:



Read and follow all the instructions and safety warnings carefully prior to use of the equipment. Failure to do so could result in equipment damage or failure of the equipment or personal injury. Hi-Force will not be held responsible for any damage to the equipment or personal injury resulting from unsafe use of the product, lack of maintenance or incorrect operation. If in doubt on the correct usage of any Hi-Force equipment, contact your nearest Hi-Force office or distributor. If the operator has not been trained on high pressure hydraulic equipment and its safe use consult your local Hi-Force sales office who can offer you training courses for operators.



All operators should ensure that all necessary personal protective equipment as specified by their employer is worn when operating any hydraulic equipment. Safety shoes, safety glasses/ visor and protective gloves should be worn at all times. All relevant risk assessments should be completed prior to use of the equipment.



**Warning:** All ancillary equipment to be used with these ranges of hydraulic manual pumps **MUST** be rated for use at the same operating pressure as the pump model to be used:-

Models AHP1120 up to and including AHP1142 – Max working Pressure - 700bar (10,000psi)

Models HAP21011 up to and including HAP21046 – Max working Pressure - 700bar (10,000psi)



Sufficient time should be allocated to planning your hydraulic system. Make sure that all the components are fit for the intended use.



Ensure there is sufficient oil capacity in the pump reservoir to fully operate the system to be used.



**DO NOT** exceed the rated pressure of the pump or the rated capacity of the system to be used. Under no circumstances ever tamper with the internal safety relief valve of the pump.



Keep hydraulic pumps away from flames and direct heat.

Hydraulic pumps must only be serviced by a qualified technician.

To protect your warranty, only use Hi-Force's hydraulic oil.

Immediately replace any worn or damaged parts using genuine Hi-Force parts only.

The system operating pressure must not exceed the pressure rating of the lowest component in the system. Where possible, use a pressure gauge to monitor the system.

Avoid damaging hydraulic hose. Always route hoses to ensure that they are free from sharp bends and kinks. Using a bent or kinked hose will cause severe back-pressure and can also lead to the failure of the hose.



**Never** lift or carry any hydraulic components by the hose or hoses connected to them.

**Do not** handle a pressurized hydraulic hose. Oil escaping under pressure from a ruptured hose can penetrate the skin and lead to a serious medical emergency and in certain cases death. Should this incident happen medical attention must be sought immediately.

## INSTRUCTION MANUAL – AIR DRIVEN HYDRAULIC PUMPS:

**Model Series: AHP1120, AHP1120R, AHP1121, AHP1121R, AHP1122, AHP1122R, AHP1141, AHP1142, HAP21011, HAP21012, HAP21014, HAP21016, HAP21021, HAP21022, HAP21024, HAP21026, HAP21031, HAP21032, HAP21034, HAP21036, HAP21041, HAP21042, HAP21044, HAP21046,**

**Always** operate the system under no load condition prior to the actual lift to ensure that no air is trapped in the hydraulic circuit.

**Do not** drop or place heavy objects on a hydraulic hose as this will cause internal damage to the hose which could result in rupture when the hose is pressurized and could result in serious damage to components, and possible serious personal injury to operating personnel.

**WARRANTY AND ABSOLVES THE MANUFACTURER FROM ALL LIABILITY**

### 3.0 Description AHP series Air Driven Pumps.

The device supplied is an air-powered hydraulic pump that converts a compressed air supply into a pressurized hydraulic flow (see "Technical specifications" – table below **Fig 2**).

The pump can be utilized to power single and double acting hydraulic cylinders; in the latter case a directional control valve between pump and cylinder is required. The filler/breather plug can be removed and used as a return line. (or select model AHP 1141/ 1142).

Any other uses of the pump shall be considered improper and can cause serious accidents. The manufacturer declines all liability for damages resulting from improper use of the pump.

### The main components of the pump

**Note:** Models ending with "R" (AHP1120R/ 1121R/ 1122R) are operated with a hand pendant instead of a treadle (Fig 16).

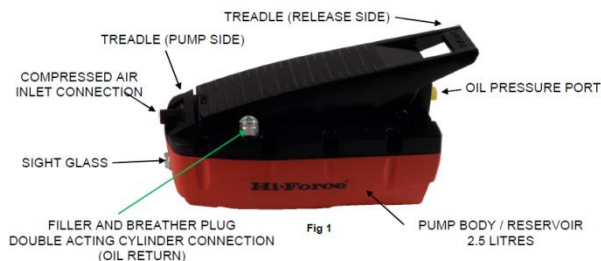

### 4.0 Safety:

Observe all the following safety rules. They are of the maximum importance for your own safety and the safety of others. In addition to the safety warnings in this section, please also take note of all safety related issues in other sections of this manual.

- **DO NOT TAMPER WITH THE PROTECTIONS AND SAFETY DEVICES AND DO NOT MODIFY THE PUMP IN ANY WAY TO AVOID CREATING POTENTIALLY HAZARDOUS SITUATIONS FOR WHICH THE OPERATOR OR THE SERVICE TECHNICIAN IS UNPREPARED.**
- **REMOVING OR TAMPERING WITH ANY OF THE SAFETY DEVICES ON THE PUMP AUTOMATICALLY INVALIDATES THE**

**Fig 2**

Model number	AHP 1120 / AHP 1120R	AHP 1121 / AHP 1121R	AHP 1122 / AHP 1122 R	AHP 1141	AHP 1142
Valve type	2-way	2-way	2-way	4-way	4-way
Maximum air inlet pressure	10 Bar	10 Bar	10 Bar	10 Bar	
Maximum hydraulic working pressure	700 Bar	700 Bar	700 Bar	700 Bar	700 Bar
Maximum rated flow rate	0.8 l/min	0.8 l/min	0.8 l/min	0.8 l/min	0.8 l/min
Air connection (standard)	1/4" G	1/4" G	1/4" G	1/4" G	1/4" G
Oil connection (standard)	3/8" NPTF	3/8" NPTF	3/8" NPTF	3/8" NPTF	3/8" NPTF
Maximum weight (without oil)	4,65 kgs	9,00 kgs	17,80 kgs	9,00 kgs	18,30 kgs
Tank capacity	2,4 litres	5,0 litres	10 litres	5,0 litres	10 litres
Noise level	75 dB(A) / 1m	75 dB(A) / 1m	75 dB(A) / 1m	75 dB(A) / 1m	75 dB(A) / 1m

### 5.0 Installation and start up:

If these instructions are disregarded, the person who is responsible for the modifications automatically assumes full liability for any accidents that may occur during use of the pump.

Pump model AHP1120 / AHP1120R / AHP1121 / AHP1121R / AHP1122 / AHP1122R / AHP1141 / AHP1142 can be installed in a horizontal or vertical position.

### 5.1. Filling the reservoir (if the pump is supplied without oil)

The table above (Fig 2.) shows the oil quantities required to fill the pump reservoir. The table also shows the actual usable oil capacities. Use only **HI-FORCE HFO46 oil** for your AHP Pump.

The manufacturer shall not be held responsible for injury to people or damage to property caused by the use of incorrect hydraulic oil.

Damage to the pump resulting from the above mentioned causes is not covered by warranty.

- Use a slotted tip screwdriver to remove the filler plug (Fig:1)
- Pour the correct quantity of oil into the reservoir (see table at Fig:2)
- Clean the edges of the filler opening with a clean cloth and refit the plug, pressing it down fully.

### 5.2.1 - Pump hydraulic connections Models AHP1120/ AHP1121/ AHP1122

- Connect the hydraulic pressure hose to (Port A Fig:14). The hose must be fitted

## INSTRUCTION MANUAL – AIR DRIVEN HYDRAULIC PUMPS:

**Model Series: AHP1120, AHP1120R, AHP1121, AHP1121R, AHP1122, AHP1122R, AHP1141, AHP1142, HAP21011, HAP21012, HAP21014, HAP21016, HAP21021, HAP21022, HAP21024, HAP21026, HAP21031, HAP21032, HAP21034, HAP21036, HAP21041, HAP21042, HAP21044, HAP21046,**

with a 3/8" NPTF fitting after binding the thread with Teflon tape.

- Unscrew the breather screw (Fig: 6) by three or four turns using an appropriate screwdriver.

### 5.2.2 - Pump hydraulic connections Models AHP1141/ AHP1142

- Connect the hydraulic pressure hose to the outlet port (Port A Fig 5) and the reservoir port (Port B Fig 5), the hose must be fitted with a 3/8" NPTF fitting after binding the thread with Teflon tape.
- Use a slotted tip screwdriver to extract the breather plug to the first click (position D in Fig 8)

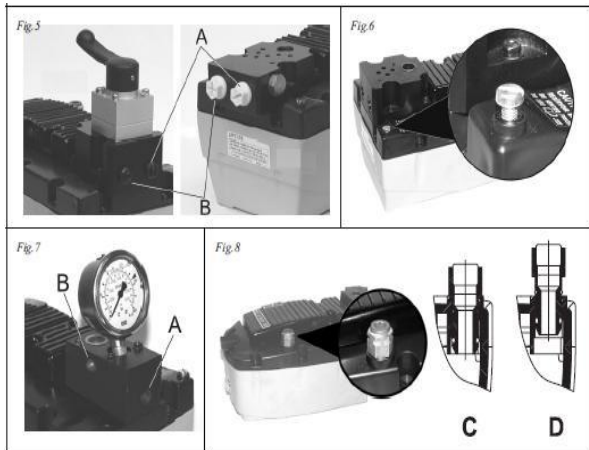

### 5.2.3 Pump hydraulic connections:

#### AHP1120R/AHP1121R/AHP1122R

- Connect the hydraulic pressure hose to (Port A Fig:14). The hose must be fitted with a 3/8" NPTF fitting after binding the thread with Teflon tape.
- Unscrew the breather screw (Fig: 6) by three or four turns using an appropriate screwdriver.

### 5.3 Connecting the compressed air line.

- Select a quick coupler that is compatible with the air-line supply and connect it to the air inlet connection (Fig. 1)

## 6: Operation

### 6.1 AHP1120/AHP1121/AHP1122.

- To start the pump press down on the treadle with your foot (Marked: PUMP Fig. 14). This will make the pump deliver pressurized oil to the connected cylinder/tool.
- When the treadle pedal is released the pump will stop delivering oil but the pressure/load in the system is maintained.
- To return the system pressure/load to zero, press the treadle in the area marked "RELEASE" (Fig: 15)



### 6.2 AHP1141 and AHP1142.

These units are fitted with 4/3 way directional control valves for use with double acting cylinders.

**Position 1 (Fig11/a)** - oil is sent to Port 'B' and returns to the reservoir via Port 'A' (Fig 5)

**Position 2 (Fig11/b)** - locked position. Ports 'A' and 'B' are closed and the Oil flow returns to the reservoir.

## INSTRUCTION MANUAL – AIR DRIVEN HYDRAULIC PUMPS:

**Model Series: AHP1120, AHP1120R, AHP1121, AHP1121R, AHP1122, AHP1122R, AHP1141, AHP1142, HAP21011, HAP21012, HAP21014, HAP21016, HAP21021, HAP21022, HAP21024, HAP21026, HAP21031, HAP21032, HAP21034, HAP21036, HAP21041, HAP21042, HAP21044, HAP21046,**

**Position 3 (Fig11/c)** - oil is sent to Port 'A' and returns to the reservoir via Port 'B'.

### 6.3 AHP1120R/AHP1121R/AHP1122R (Hand Pendant Operation).



#### WARNING:

Immediately after the pump installation, the circuit may contain air locks that prevent pressurization. If the pump is unable to pressurize the oil circuit, proceed as described below.

The following operations are the only actions which can be to the pump using the hands. Under normal circumstances the must be used by foot operation.

- If the pump is mounted vertically, disassemble it and place it in a horizontal position on the floor.
- Place the treadle at the "PUMP" side. There is a flat pushbutton beneath the treadle.
- Use one hand to press the "RELEASE" side of the treadle while pressing the pushbutton under the "PUMP" side with your other hand (fig.10, page 13). Maintain the pressure on the "RELEASE" side and the "PUMP" pushbutton for about 15 seconds.

The pump should now work correctly. If you still have problems, repeat the above mentioned procedure.

The AHP pump is extremely simple to use:

- To activate the pump press the button marked "PUMP" on the hand pendant (Fig. 16).The pump will start to deliver pressurized oil and thereby cause the connected cylinder to advance.
- When the button is released, the pump stops but the pressure is maintained on the oil side so that the connected cylinder holds the load in the position it has reached.
- To return the pressure to zero and hence retract the cylinder to its starting position, press the button marked "RELEASE" (Fig 16).

**Fig: 16**

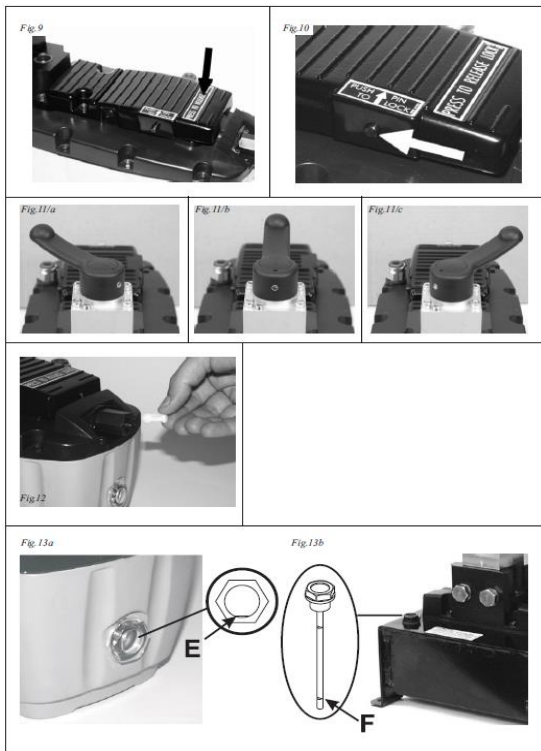

## 7 - MAINTENANCE

The routine maintenance work described below must be performed exclusively by a skilled technician who has a thorough knowledge of the pump and its operation and who has read this manual completely. Maintenance must be carried out with maximum caution to avoid possible accidents. This chapter describes the only maintenance procedures permitted. Execution of any unauthorised maintenance work will automatically invalidate the warranty and free the manufacturer from all liability.

### 7.1 - Checking connections

Check the hydraulic and pneumatic connections once a week. Ensure that the connections on the pump are screwed down tightly and show no signs of breakage, cracks or other damage. Ensure that the hoses are not damaged in any way (cuts, abrasion, cracks, etc.).



## INSTRUCTION MANUAL – AIR DRIVEN HYDRAULIC PUMPS:

**Model Series: AHP1120, AHP1120R, AHP1121, AHP1121R, AHP1122, AHP1122R, AHP1141, AHP1142, HAP21011, HAP21012, HAP21014, HAP21016, HAP21021, HAP21022, HAP21024, HAP21026, HAP21031, HAP21032, HAP21034, HAP21036, HAP21041, HAP21042, HAP21044, HAP21046,**

### 7.2 - Cleaning the air filter

There is an air filter inside the air inlet connection (**Fig 12**).

- Use a slotted tip screwdriver of the appropriate size to unscrew the filter from the air inlet connection until it is extracted.
- Clean the filter with compressed air and then refit and screw it into position. Do not over-tighten the filter or damage may ensue.
- Reconnect the air-line quick coupler after binding the thread with Teflon tape.
- If the air filter is excessively contaminated or damaged, it must be renewed.
- Order a new filter from the manufacturer, referring to the list of spare parts at the end of this manual.

#### 7.3.1 - Checking the hydraulic oil on the 2,5 Litre pump (AHP1120/AHP1120R)

Periodically check that the pump contains the correct quantity of hydraulic oil by checking the level on the sight glass (**Fig 13**). If the oil level, with cylinder retracted, is below minimum (**E, Fig 13a**), refill using the recommended types of oil.

#### 7.3.2 - Checking the hydraulic oil on the 5/10 Litre pump (AHP1121(R)/ 1122(R)/ 1141/ 1142)

Periodically check the oil level, which must be between the two notches on the oil cap dipstick (**F in Fig 13b**).

### 7.4 - Hydraulic oil change

Change the oil at intervals of 250 duty hours. This operation must be performed when the cylinder is fully retracted: **USE ONLY HI-FORCE HFO46 OIL for your AHP Pump.**

- If the pump is mounted vertically, disassemble it and position it horizontally.
- Use a slotted tip screwdriver to remove the filler plug (**Fig 1**).
- Empty the pump of oil by turning it upside down over a suitable container.
- Allow all the oil to flow into the container and then fill the pump with the quantity and type of new oil specified above.
- Clean the filler opening with a clean cloth and refit the plug, pressing it fully down or, if necessary, to the partially inserted breather position.

### 7.5 - Troubleshooting

The chart below describes the possible issues that could occur during operation of the pump, together with an indication of the appropriate corrective action. If the prescribed action fails to solve the problem, contact the manufacturer.

PROBLEM	POSSIBLE CAUSE	CORRECTIVE ACTION
Pump cannot be started	Compressed air line closed or clogged	Check compressed air supply to pump
Pump stops working under load	Insufficient air pressure	Check compressed air supply to pump is between 2.8 and 10Bar
	Air filter dirty or clogged	Clean or Renew
Pump operates but no pressurized oil is delivered	Oil leak in the main hydraulic circuit.	Check the circuit for leaks and repair as necessary.
	Pump internal leak	Check for leaks and return pump to manufacturer for repair
	Low oil level	Check level and top up as necessary
Pump fails to reach maximum pressure	Insufficient air pressure	Check compressed air supply to pump is between 2.8 and 10Bar
	Internal relief valve incorrectly set.	Contact the manufacturer
	Oil leak in the main hydraulic circuit	Check for oil leaks and ask the manufacturer
Pump delivers pressurized oil but load is not lifting	Excess load	Reduce
	Oil circulation fault	Check if pipelines are obstructed or if cylinder is working correctly
Piston retracts although treadle is not pressed on RELEASE side	Oil leak in the main hydraulic circuit	Check the circuit for leaks and repair as necessary.
	Pump internal fault	Check for leaks and ask the manufacturer
Piston fails to perform retract stroke (single acting cylinder)	Oil pressure line obstructed or coupling incorrectly connected	Check oil pressure line.
	If piston is designed to return under gravity, ensure load is sufficient	Increase load on cylinder
	Cylinder spring broken	Repair
Piston fails to perform retract stroke (single acting cylinder)	Cylinder release valve not working	Repair cylinder
	Oil pressure line obstructed or coupling incorrectly connected	Check oil pressure line.
Pump flow rate insufficient	Insufficient air pressure.	Check compressed air supply to pump is between 2.8 and 10Bar.
	Air filter dirty or clogged.	Clean or Renew.
	Reservoir breather plug or screw not opened	Open breather Plug or screw as described in section 5

## INSTRUCTION MANUAL – AIR DRIVEN HYDRAULIC PUMPS:

**Model Series: AHP1120, AHP1120R, AHP1121, AHP1121R, AHP1122, AHP1122R, AHP1141, AHP1142, HAP21011, HAP21012, HAP21014, HAP21016, HAP21021, HAP21022, HAP21024, HAP21026, HAP21031, HAP21032, HAP21034, HAP21036, HAP21041, HAP21042, HAP21044, HAP21046,**

### 8.0 Description HAP series of Air Driven Pumps

Hi-Force HAP series pumps are designed to operate high pressure hydraulic cylinders and tools with a maximum working pressure of 700 bar. These instructions cover all HAP2-3 series models. Refer to nameplate on pump for model identification.

Common models and uses are given below:

MODEL	HYDRAULIC CONNECTIONS
HAP21011 HAP21012 HAP21014 HAP21016	No control valve fitted. Pump (P) and tank (T) connections for single and double acting cylinders controlled by remote mounted valves.
HAP21021 HAP21022 HAP21024 HAP21026	2 way valve for operating single acting cylinders and tools requiring advance and retract but no "hold" function. For example crimpers and cutters.
HAP21031 HAP21032 HAP21034 HAP21036	3 way valve for operating single acting cylinders requiring advance, retract and central load hold position. For example simple lifting operations
HAP21041 HAP21042 HAP31044 HAP21046	4 way valve for operating double acting cylinders requiring advance, retract and central load hold position. For example lifting and positioning requiring more control.

### 9.0 Safety:

**FAILURE TO OBSERVE THE FOLLOWING WARNINGS COULD RESULT IN SERIOUS BODILY INJURY.**

- Ensure that all equipment connected to the pump is in good condition and is all rated for 700 bar operating pressure.
- Always stand the pump on a stable level surface during operation.
- Never invert the pump or lay it on its side either in use, transport or in storage.
- Inspect hoses regularly for damage and wear. Do not use hoses that are frayed, abraded or leaking.
- Never move the pump by pulling the hoses.
- Do not work with hoses sharply bent or kinked.
- Do not handle hoses that are pressurised. Oil escaping under

pressure can penetrate the skin causing serious injury. If oil is injected under the skin see a doctor immediately.

- Never pressurise uncoupled couplers.
- Always use eye, ear and hand protective equipment when using this pump and associated equipment

### 10.0 Identification of Components.

Refer to diagrams on following pages.

1. Oil reservoir
2. Hydraulic Oil level gauge
3. Oil filler breather cap
4. Motor
5. Silencer
6. Adjustable pressure relief valve
7. Hydraulic directional control valve – if fitted (type will vary)
8. Hydraulic service connections
9. Hydraulic oil drain plug
10. Roll frame (optional)

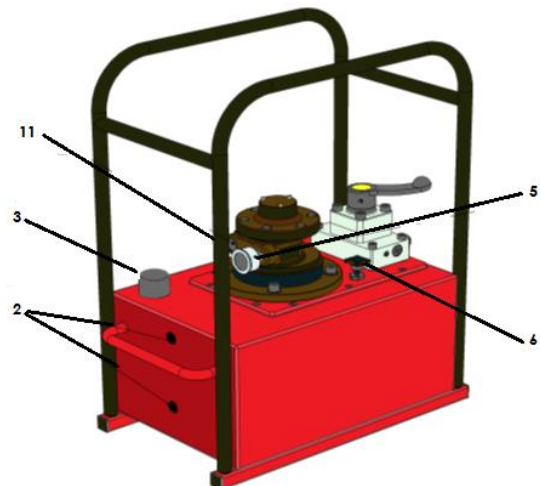
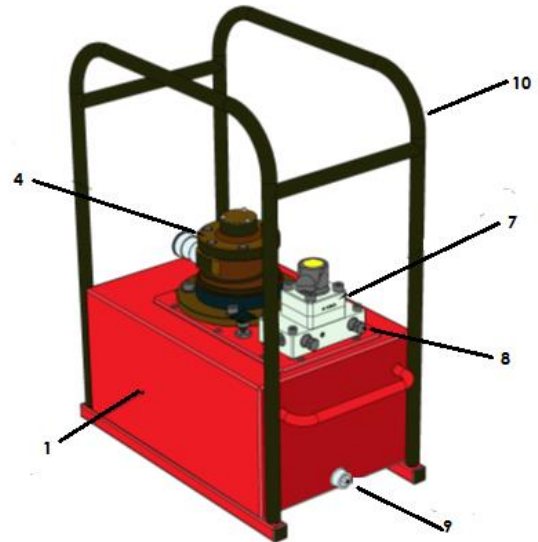

## INSTRUCTION MANUAL – AIR DRIVEN HYDRAULIC PUMPS:

**Model Series: AHP1120, AHP1120R, AHP1121, AHP1121R, AHP1122, AHP1122R, AHP1141, AHP1142, HAP21011, HAP21012, HAP21014, HAP21016, HAP21021, HAP21022, HAP21024, HAP21026, HAP21031, HAP21032, HAP21034, HAP21036, HAP21041, HAP21042, HAP21044, HAP21046,**

### 11.0 Preparing the Pump for first use:

1. Immediately after unpacking, examine the pump for signs of transit damage and if found contact the shipping company.
  2. Establish the oil level in the oil reservoir using the level gauge on the end of the tank. Depending on the shipping method used, the reservoir may either be supplied full or empty. If the reservoir is empty it must be correctly filled before use. Remove the temporary transit plate which is fitted in the position of the filler breather cap (3) by undoing the 3 screws. Fit the filler breather cap (packed separately) using the 3 screws which held the transit plate.
  3. To fill the reservoir: Remove the filler cap (3) and fill the tank with clean HFO46 oil to the upper level indicator (2).
  4. Connect the air supply to the Motor air inlet (11). Max inlet pressure 7 bar. It is recommended that a filter and lubricator are incorporated in the air supply.
  5. Ensure your air supply circuit includes a ball or sliding valve close at hand, which can be used to control the air supply.
  6. Remove hexagon headed plugs and make hydraulic connections to service ports (8). These ports have a 3/8" NPT female thread and the corresponding male connections should be wrapped with PTFE tape or other suitable sealant.
  7. Ensure the lever of the hydraulic directional control valve (7) is in the neutral position. This is fully anticlockwise for models with 2 way valve (HAP21021, HAP21022, HAP21024, HAP21026) and the central position for models with 3 or 4 way valves (HAP21031, HAP21032, HAP21034, HAP21036, HAP21041, HAP21042, HAP21044, HAP21046) Where valves are remotely mounted, ensure these are adjusted such that pressure will not build up during the starting operation.
1. With all hydraulic connections made and air motor running, operate the directional control valve (7) if fitted to control the cylinders or tools in use.
  2. For pumps with 2 way valves: Turning the lever full clockwise will supply oil to the service port and advance the cylinder. Turning the lever anticlockwise will retract the cylinder.
  3. For pumps with 3 way valves: Mid position is the load hold position. Moving the lever so that it is above the service port (anti-clockwise) will supply oil to the port and advance the cylinder. Moving the lever away from the service port will connect the service port to tank and retract the cylinder.
  4. For pumps with 4 way valves: Mid position is the load hold position. Moving the lever so that it is above either service port will supply oil to that port and connect the opposite port to tank.
  5. The pump is fitted with an adjustable pressure relief valve (6) to restrict the out-put pressure to any desired value up to the maximum working pressure of the pump. To increase the relief valve setting turn the control knob clockwise. To decrease the relief valve setting turn the control knob anticlockwise. Leaving the pump running for extended periods with the relief valve operating will cause the oil to overheat.
  6. Ensure that the oil level does not fall below the minimum level as shown by the lower indicator (2)

### 11.1 Operation of the Pump:

Hi-Force does not necessarily know what equipment this pump will power. Read and understand the appropriate operating instructions relating to the equipment in use.

### 12.0 Maintenance:

**In order to ensure the longest service life and best performance from your pump, regularly carry out the following routine maintenance.**

- Inspect the pump for damage after each use
- If a gauge is fitted to the pump ensure it is regularly checked to ensure it is within its calibration limits.
- Regularly check the oil level in the pump reservoir by means of the oil level gauge ( item 2 in the diagrams)
- Never run the pump with the oil level in the reservoir below its bottom limit.

**INSTRUCTION MANUAL – AIR DRIVEN HYDRAULIC PUMPS:**

**Model Series: AHP1120, AHP1120R, AHP1121, AHP1121R, AHP1122, AHP1122R, AHP1141, AHP1142, HAP21011, HAP21012, HAP21014, HAP21016, HAP21021, HAP21022, HAP21024, HAP21026, HAP21031, HAP21032, HAP21034, HAP21036, HAP21041, HAP21042, HAP21044, HAP21046,**

- Change the oil every 500 working hours  
always only use **Hi-Force HFO46 oil**
- Have the pump serviced regularly by a  
**Hi-Force** authorised repair centre.