



EVOTORQUE®2



The EvoTorque®2 is an electronic torque tool designed to accurately apply torque to threaded fasteners. Tools are factory calibrated to $\pm 3\%$ of reading. The unique 'intelligent joint sensing' technology continually measures the joint during tightening and when necessary, employs dynamic braking to avoid torque over-shoot due to motor inertia. Consequently, EvoTorque®2 can apply torque accurately over a wide range of joint rates from hard (high torque rate) through to soft (low torque rate). All EvoTorque®2 tools are highly tolerant of supply voltage and frequency variation. If the supply voltage is outside of tolerance then, as a safety feature, the tool will be prevented from starting.

The EvoTorque®2 has the ability to memorise multiple targets, work IDs, user IDs and readings. A work sequence (flow) can be performed on the EvoTorque®2, taking the user through a pre-defined tightening sequence. The tool has four modes of operation: Torque, Torque & Angle, Torque & Angle with Final Torque and Torque Audit. The unique Audit Mode is a sophisticated feature for testing pre-tightened bolts with minimal impact on the original fastening torque and can provide quality control data for monitoring joint performance over time. EvoTorque®2 builds on the original tool with these additional features:

- Multiple units of torque measurement, N-m, lbf-ft, ft-lb and kgf-m
- Calibrated from 20% to 100% of tool range
- Torque, Torque & Angle and Torque Audit modes available
- In Torque & Angle Mode and Audit Mode, torque can be set from 10% of tool maximum
- Display and on-board storage of final torque or torque and angle values
- Memory capacity for 3,000 readings, time and date stamped
- Clear indication of successful joint application
- USB and Bluetooth® 4.0 data transfer (also called Bluetooth® Smart)
- Complementary PC software 'EvoLog' for data management and tool configuration
- 12 user IDs can be downloaded to the tool and results can be stored against individual users
- 20 unique stand-alone targets plus 20 unique work group targets for each work group
- Results can be output in CSV (comma-separated values) format for users not able to use EvoLog
- Ability to produce and store real time graphs via EvoLog
- Torque & Angle with Final Torque
- 'Usage' counter gives the ability to see the amount of times the tool has been used since the last reset
- 'Operation Direction' feature designed primarily for undoing bolts. When doing sequence tightening, it is now possible to undo an incorrectly tightened bolt without interrupting the sequence
- Two stage tightening gives faster application of a Snug Torque & Angle Target
- 'Turn Angle' option can be used to check if bolts have already been tightened in an assembly process
- Tool can be integrated into third party control systems
- Two different lock levels, lock level 1 as per previous lock, lock level 2 will not allow user to exit the run screen or change the target
- Maximum Audit Mode target angle of 720°
- Supplied with a traceable calibration certificate for torque and angle as standard. Calibrated from 20% to 100% of tools maximum torque capacity, clockwise only



EVOTORQUE®2



Colour OLED display shows torque and angle values



Display can be powered up independently of tool for data transfer (via USB)



Built in Bluetooth® for wireless data transfer



Communication between tool and PC either wirelessly using Bluetooth® 4.0 or wired using supplied USB cable

EvoTorque®2's intelligent joint sensing technology always detects which type of bolt you are working with.

Hard joints

(High Torque Rate*)

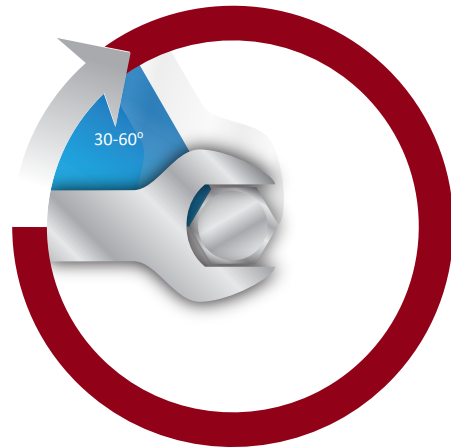

Joints completed within the range 30° - 60°

Soft joints

(Low Torque Rate*)

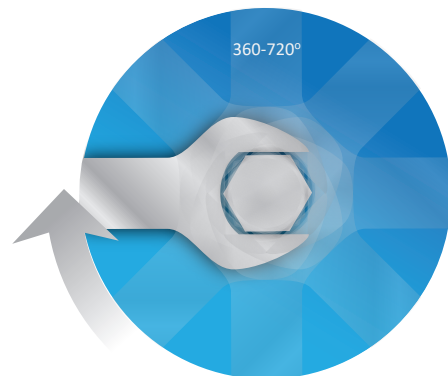

Joints completed within the range 360° - 720°

*High torque rate and low torque rate as defined by ISO 5393 'Rotary tools for threaded fasteners- Performance test method'

The EvoTorque®2 has been designed to complete joints of 30° and above to within the tools ±3% accuracy. For joints below 30° use the tools audit mode feature.



EVOTORQUE®2



Traditional electronic torque tools give vastly different results depending on the joint type. Norbar's 'intelligent joint sensing' technology eliminates these issues so that you can be confident in your bolting work.

Typical of present generation

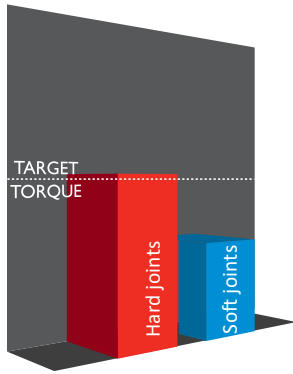

New generation EvoTorque®2

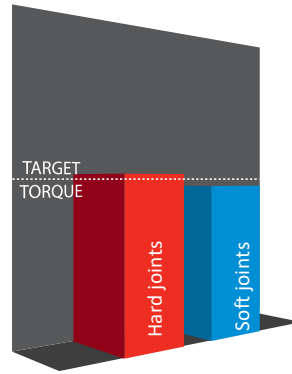

ET2-72 (1000 & 1350)

ET2-72 (2000)

ET2-80 (2700)

ET2-92 (4000)

ET2-119 (7000)

11	EVOTORQUE 2 - 110 V
180230.B06	ET2-72-1000-110, ¾" sq. dr., 200 - 1,000 N-m
180231.B06	ET2-72-1350-110, ¾" sq. dr., 270 - 1,350 N-m
180232.B08	ET2-72-2000-110, 1" sq. dr., 400 - 2,000 N-m
180239.B08	ET2-80-2700-110, 1" sq. dr., 540 - 2,700 N-m
180238.B08	ET2-92-4000-110, 1" sq. dr., 800 - 4,000 N-m
180236.B12	ET2-119-7000-110, 1½" sq. dr., 1,400 - 7,000 N-m

11	EVOTORQUE 2 - 230 V
180220.B06	ET2-72-1000-230, ¾" sq. dr., 200 - 1,000 N-m
180221.B06	ET2-72-1350-230, ¾" sq. dr., 270 - 1,350 N-m
180222.B08	ET2-72-2000-230, 1" sq. dr., 400 - 2,000 N-m
180229.B08	ET2-80-2700-230, 1" sq. dr., 540 - 2,700 N-m
180228.B08	ET2-92-4000-230, 1" sq. dr., 800 - 4,000 N-m
180226.B12	ET2-119-7000-230, 1½" sq. dr., 1,400 - 7,000 N-m

The EvoTorque®2 is supplied in a cardboard box as standard, if a sturdier case is required Norbar can provide a Peli Case at an additional charge. Please add .PEL on to the end of the part number when ordering. For tools fitted with a Right Angle Gearbox, add .RAPEL.



Standard Box



Optional Peli Case
Part No. 26969 or 26971



EVOTORQUE®2

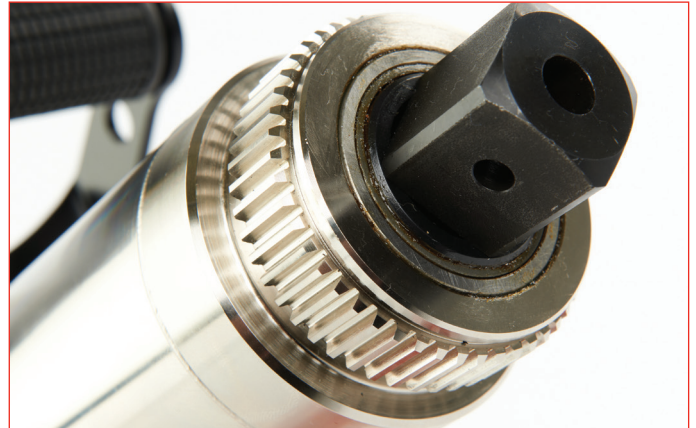

Model	ET2-72-1000 ET2-72-1350	ET2-72-2000	ET2-80-2700	ET2-92-4000	ET2-119-7000	
Part Number	180230.B06 180220.B06 180231.B06 180221.B06	180232.B08 180222.B08	180239.B08 180229.B08	180238.B08 180228.B08	180236.B12 180226.B12	
Output Speed (rpm)	21 (ET-72-1000) 17 (ET-72-1350)	11	10	6	3.3	
Dimensions (mm)	∅D max.	72	72	80	92	119
	H1	45	45	45	45	45
	H2	317	317	317	317	317
	H3	109	109	109	109	109
	L	366	407	363	417	440
	R1	71	76	76	70	90
	R2 min. R2 max.	124 167	124 167	124 167	125 175	162 210
Tool Weight (kg)	10.4	10.8	10.8	12.9	16.8	
Reaction Weight (kg)	1.5	1.5	1.5	2.6	3.9	

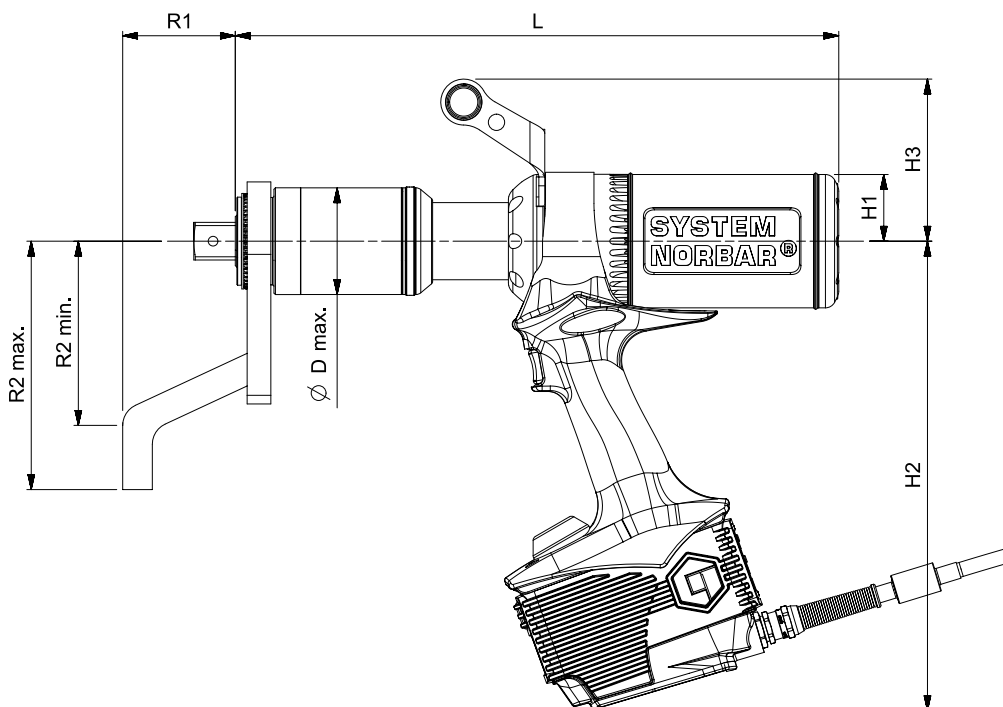

Patented in the UK and Germany (EP2699389) and in the USA (US9676086).