

REVISION

1	6088
<b>2</b>	<b>6180</b>
3	
4	
5	
6	
7	
8	
9	
10	
11	
12	
13	
14	
15	
16	
17	
18	
19	
20	

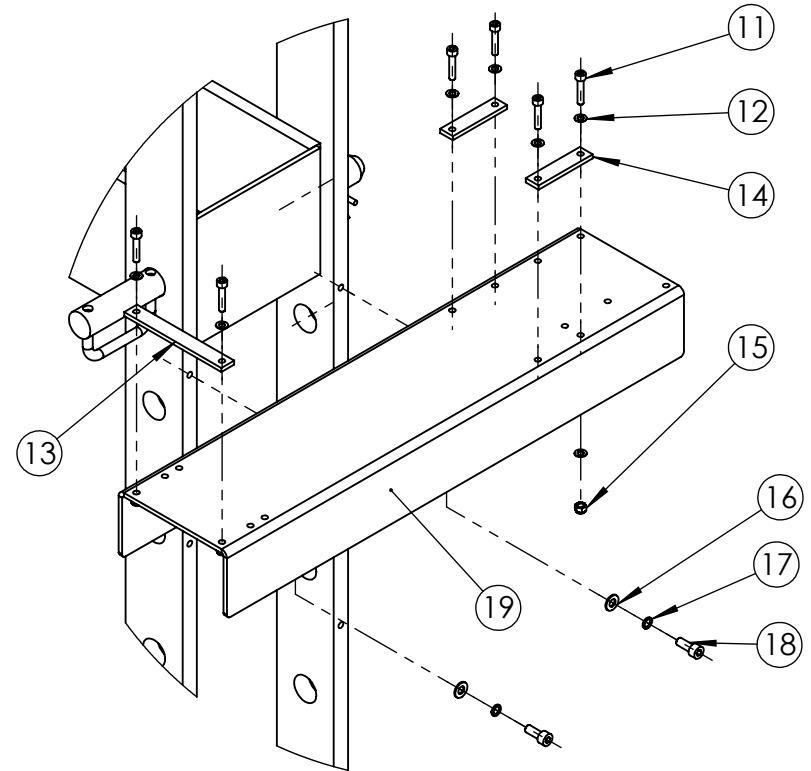
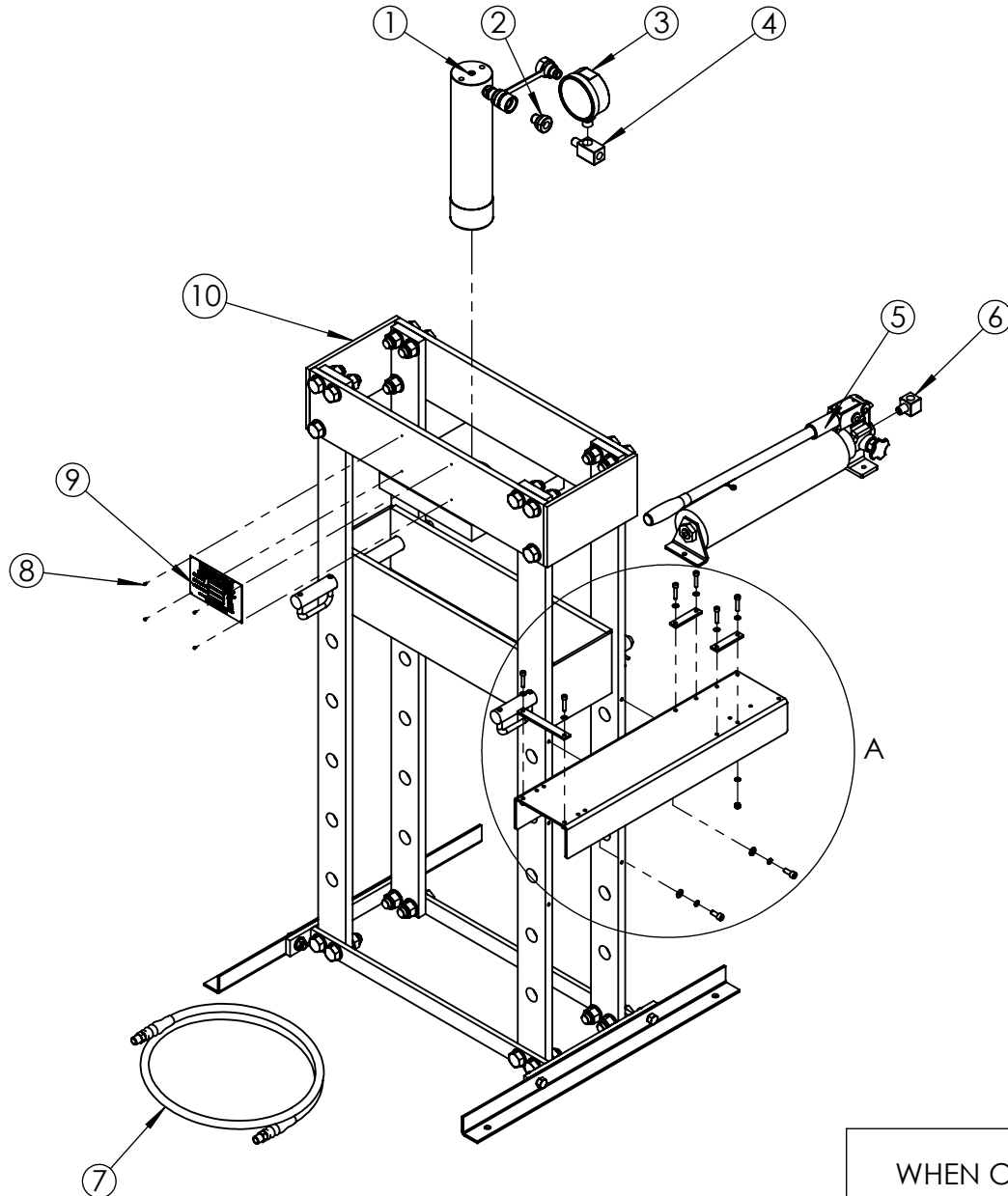

DETAIL A  
SCALE 2 : 15

**IMPORTANT**  
WHEN ORDERING SPARES YOU MUST STATE THE FULL PART NUMBER AND THE  
PRODUCT SERIAL NUMBER - FROM THE LABEL  
TO PROTECT YOUR WARRANTY ALWAYS USE GENUINE HI-FORCE PARTS.

REVISION

1 6088

2 6180

3

4

5

6

7

8

9

10

11

12

13

14

15

16

17

18

19

20

ITEM NO.	PART NUMBER	DESCRIPTION	QTY.	SPARE PART AVAILABILITY
1	<b>HSS2510</b>	SPRING RETURN CYLINDER HSS2510	1	
2	CM1	MALE COUPLER	1	
3	HG25	PRESSURE GAUGE	1	
4	HGA1	GAUGE BLOCK	1	
5	<b>HP227</b>	HANDPUMP	1	
6	HF16	ELBOW, 3/8" NPT FEMALE TO 3/8" NPT MALE	1	
7	HH2	HYDRAULIC HOSE 2M.	1	
8	FAS002HZ001	NO.4 x 3/16 HAMMER DRIVE SCREW	4	
9	AAN025FP001	NAMEPLATE	1	X
10	<b>PAA025CH001</b>	25T PRESS FRAME	1	X
11	BLC006JD030	M6 x 30 mm HEX SOCKET CAP HEAD SCREW	6	
12	WAC006AF000	M6 ZINC WASHER	12	
13	SFC018HA002	PUMP CLAMP BRACKET	1	
14	SFC018HA003	PUMP CLAMP BRACKET	2	
15	NUC006JC000	M6 NYLOK NUT	6	
16	WAC008AB000	M8 PLAIN WASHER	2	
17	WAC008BB000	M8 ZINC PLATED SPRING WASHER	2	
18	BLC008KD020	M8 x 20 mm HEX SOCKET CAP HEAD SCREW	2	
19	SFC152HF001	HAND PUMP BRACKET	1	

NOTES:

-ALL PARTS AVAILABLE TO ORDER AS AN INDIVIDUAL SPARE PART UNLESS MARKED "X"

-FOR SUB ASSEMBLIES (ITEM NO.s 1, 5 & 10) PLEASE REFER TO THEIR INDIVIDUAL EVD's

**IMPORTANT**

WHEN ORDERING SPARES YOU MUST STATE THE FULL PART NUMBER AND THE PRODUCT SERIAL NUMBER - FROM THE LABEL TO PROTECT YOUR WARRANTY ALWAYS USE GENUINE HI-FORCE PARTS.

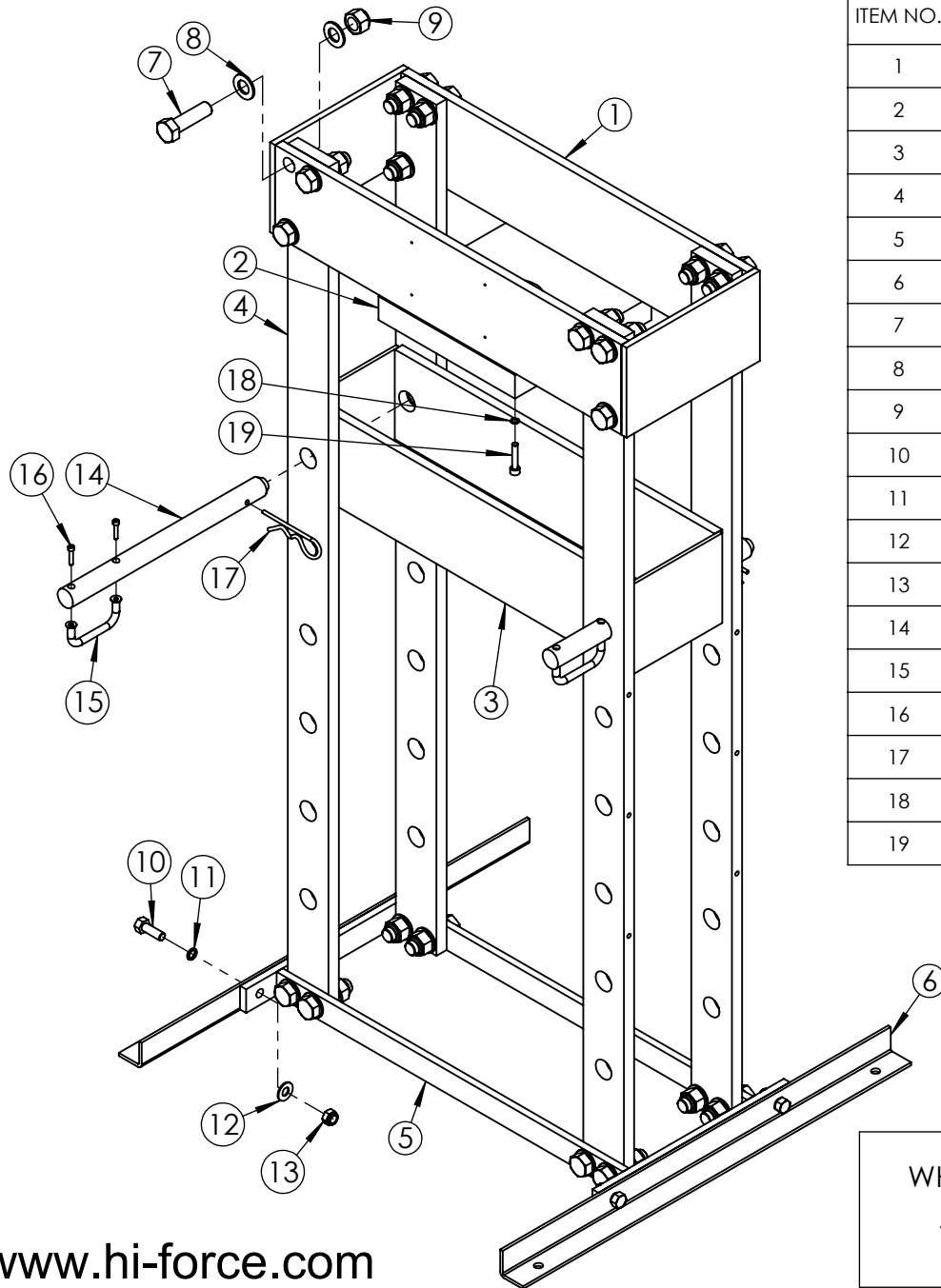

ITEM NO.	PART NUMBER	DESCRIPTION	QTY.	SPARE PARTS	SERVICE PARTS
1	PBS025HC001	25T PRESS UPPER	1	X	
2	MBC084FB001	MOUNTING BLOCK	1		
3	PBS025BC001	PRESS BED	1	X	
4	PUC025FE001	25T PRESS FRAME UPRIGHT	4	X	
5	PBS025LC001	25T PRESS BASE	1	X	
6	PFC025AF003	PRESS FOOT	2	X	
7	BLC020PA070	M20 x 70 HEX HEAD BOLT	20		
8	WAC020AB000	M20 PL WASHER	40		
9	NUC020PC000	M20 NYLOK NUT	20		
10	BLC012MB035	M12 x 35 HEX HEAD BOLT	4		
11	WAC012BB000	M12 SPRING WASHER	4		
12	WAC012AB000	M12 PLAIN WASHER	4		
13	NUC012MC000	M12 NYLOK NUT	4		
14	PLC025CP001	25T LOAD PIN	2		
15	HLC010BM003	BRIDGE HANDLE	2		
16	BLC005HD025	M5 x 25 SOCKET CAP HEAD SCREW	4		
17	STC025RA001	R CLIP	2		
18	WAC008BB000	M8 ZINC PLATED SPRING WASHER	4		
19	BLC008KD040	M8 x 40 SOCKET CAP HEAD SCREW	4		

REVISION	
1	6169
2	6180
3	6376
4	
5	
6	
7	
8	
9	
10	
11	
12	
13	
14	
15	
16	
17	
18	
19	
20	

**NOTE:**  
- ALL PARTS ARE AVAILABLE TO BE ORDERED AS SPARE PARTS (UNLESS MARKED WITH X).

**IMPORTANT**

WHEN ORDERING SPARES YOU MUST STATE THE FULL PART NUMBER AND THE PRODUCT SERIAL NUMBER - FROM THE LABEL TO PROTECT YOUR WARRANTY ALWAYS USE GENUINE HI-FORCE PARTS.