



HANDTORQUE® COMPACT SERIES



HT92/25



- Compact dimensions allow excellent access to applications and easy, safe handling
- Lightweight for torque capacity
- Supplied as standard with an aluminium reaction arm (steel reactions for HT-52). Other options are available on request, including customised reactions
- Mean torque multiplication accuracy $\pm 4\%$
- Robust, 48 tooth Anti Wind-Up Ratchet (AWUR) contains the forces generated during tightening for safe and easy operation
- Each multiplier is supplied with its own unique traceable calibration certificate allowing the accurate calculation of input torque for critical applications
- If you order a UKAS accredited calibration certificate (available at extra cost), this certificate will be provided in place of the traceable calibration certificate.

4	COMPACT SERIES
180200	HT-52/4.7, 1,000 N·m, 1/2" in 3/4" out
180201	HT-52/22.2, 1,000 N·m, 3/8" in 3/4" out
180202	HT-52/22.2, 1,000 N·m, 1/2" in 3/4" out
180203	HT-52/22.2 AWUR, 1,000 N·m, 3/8" in 3/4" out
180204	HT-52/22.2 AWUR, 1,000 N·m, 1/2" in 3/4" out
180205	HT-52/22.2 AWUR, 1,000 N·m, 3/8" in 1" out
180206	HT-52/22.2 AWUR, 1,000 N·m, 1/2" in 1" out
180208	HT-72/5.2, 1,500 N·m, 1/2" in 1" out
180209	HT-72/5.2, 1,000 N·m, 3/4" in 3/4" out
180210	HT-72/5.2, 2,000 N·m, 3/4" in 1" out
180212	HT-72/27, 2,000 N·m, 1/2" in 1" out
180214	HT-72/27 AWUR, 2,000 N·m, 1/2" in 1" out
180215	HT-92/25 AWUR, 4,000 N·m, 1/2" in 1" out
180216	HT-119/25.5 AWUR, 7,000 N·m, 1/2" in 1 1/2" out

Model	HT-52/4.7	HT-52/22.2	HT52/22.2 AWUR	HT-72/5.2	HT-72/5.2	HT-72/27	HT-72/27 AWUR	HT-92/25 AWUR	HT-119/25.5 AWUR
Part Number	180200	180201 180202	180203 180204 180205 180206	180208 180209	180210	180212	180214	180215	180216
Mean Multiplication Ratio	4.7:1	22.2:1	22.2:1	5.2:1	5.2:1	27:1	27:1	25:1	25.5:1
Dimensions (mm)	ØD max.	52	52	72	72	72	72	92	119
	H	91	116	130	140	135	137	154	212
	R1	58	58	58	67	72	72	87	117
	R2 min.	71	71	71	91	91	91	91	115
	R2 max.	131	131	131	166	166	166	166	205
Tool Weight (kg)	1.0	1.3	1.4	2.7	2.7	2.7	3.2	5.4	9.3
Reaction Weight (kg)	0.9	0.9	0.9	0.7	0.7	0.7	0.7	1.4	2.1

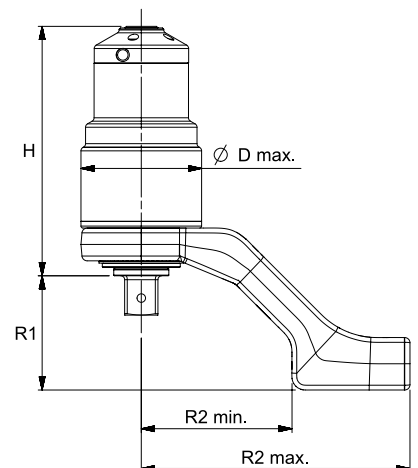



HANDTORQUE® COMPACT SERIES KITS



SpinNor (1/2") included
Part No. 19253

Multiplier & Torque Wrench Kits

For convenience, it is now possible to purchase a torque multiplier from the 'Compact Series' packaged with the appropriate torque wrench, up to 4,000 N·m. This allows the operator to arrive at the bolting application with everything needed in one robust carry case. Space has also been allowed in the carry case for accessories such as sockets.

The torque multiplier is supplied with its own unique calibration certificate and the torque wrench is supplied with a Declaration of Conformance, allowing accurate calculation of input torque to the multiplier for critical applications.

- All kits include a 'SpinNor' which aids fast reaction location
- All models include an Anti Wind-up Ratchet on the multiplier

4	HT COMPACT SERIES & TORQUE WRENCH KITS
18186	HT-52, 1,000 N·m, 3/4" out + NorTorque 60 1/2" Dual Scale
18192	HT-72, 2,000 N·m, 1" out + NorTorque 100 1/2" Dual Scale
18195	HT-92, 4,000 N·m, 1" out + NorTorque 200 1/2" Dual Scale

HANDTORQUE® STANDARD SERIES



HT 5/25

- Mean torque multiplication accuracy ±4%
- High ratios allow the use of a small torque wrench, multipliers can be used where access is limited
- Anti Wind-Up Ratchet available on high ratio models
- Other reaction styles can be designed to suit specific applications
- Electronic torque transducers can be fitted for precise torque monitoring, see page 105
- Other models available up to 300,000 N·m
- If calibration is required, a UKAS accredited calibration certificate may be ordered (at extra cost) up to 6,000 N·m

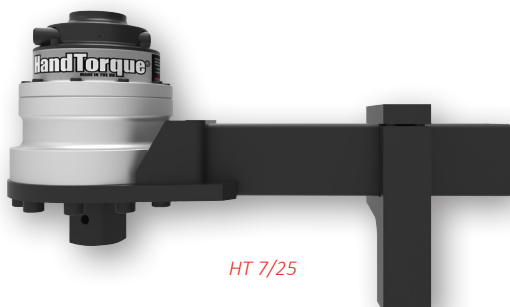

HT 7/25

4	STANDARD SERIES
16010	HT 1/5, 1,700 N·m, 1/2" in 3/4" out
16012.HD	HT 2/5, 1,700 N·m, 3/4" in 1" out
16034.HD	HT 2/25, 1,700 N·m, 1/2" in 1" out
16089.HD	HT 2/25 AWUR, 1,700 N·m, 1/2" in 1" out
16014	HT 5/5, 3,400 N·m, 3/4" in 1" out
16028	HT 5/25, 3,400 N·m, 1/2" in 1" out
16090	HT 5/25 AWUR, 3,400 N·m, 1/2" in 1" out
16016	HT 6/5, 3,400 N·m, 3/4" in 1 1/2" out
16024	HT 6/25, 3,400 N·m, 1/2" in 1 1/2" out
16092	HT 6/25 AWUR, 3,400 N·m, 1/2" in 1 1/2" out
16093	HT 6/125 AWUR, 3,400 N·m, 1/2" in 1 1/2" out
16067	HT 7/5, 6,000 N·m, 3/4" in 1 1/2" out
16018	HT 7/25, 6,000 N·m, 1/2" in 1 1/2" out
16065	HT 7/25 AWUR, 6,000 N·m, 1/2" in 1 1/2" out
16068	HT 7/125 AWUR, 6,000 N·m, 1/2" in 1 1/2" out
16059	HT 9/25, 9,500 N·m, 3/4" in 1 1/2" out
16070	HT 9/25 AWUR, 9,500 N·m, 3/4" in 1 1/2" out
16071	HT 9/125 AWUR, 9,500 N·m, 1/2" in 1 1/2" out
16082	HT 11/25, 20,000 N·m, 3/4" in 2 1/2" out
16049	HT 11/125 AWUR, 20,000 N·m, 1/2" in 2 1/2" out
16053	HT 13/125 AWUR, 47,500 N·m, 1/2" in 2 1/2" out

Other gear ratios may be available upon request.

If AWUR is not required please enquire for part number.

HT 13/125 fitted with weld prepared reaction ring as standard.

AWUR = Anti Wind-Up Ratchet. See page 49

NOTE: Model name does not reflect multiplication ratios, see mean multiplication ratios on page 54

For spares kits for Norbar multipliers, please see page 144.