

Heavy Duty Wheels

Model K, G



Range of application:

- Used in areas threatened by corrosion.
- For a particularly quiet running, which doesn't damage the ground.
- When lower carrying capacity and sturdiness lower than steel is required.
- In cases of minimal electric conductivity (plastic).
- For transporting loads at a maximum speed of 100 m/min.

Characteristics of the models ...K and ...G:

- Solid basic construction with ball bearings.
- Delivered with various mountings.
- Special construction to suit customer requirements.
- Passed the DIN 4422 test at the material research laboratory for plastic wheel 150 K.

■ Wheels (without castors) – Drawing No. R2



Hints on use:

- Construction free of maintenance with advantages over the steel wheel particularly in maritime environments or where is danger of corrosion.
- Can be combined with fixed castors and swivel castors.
- Material doesn't damage the ground, but is more susceptible than steel when handled roughly.

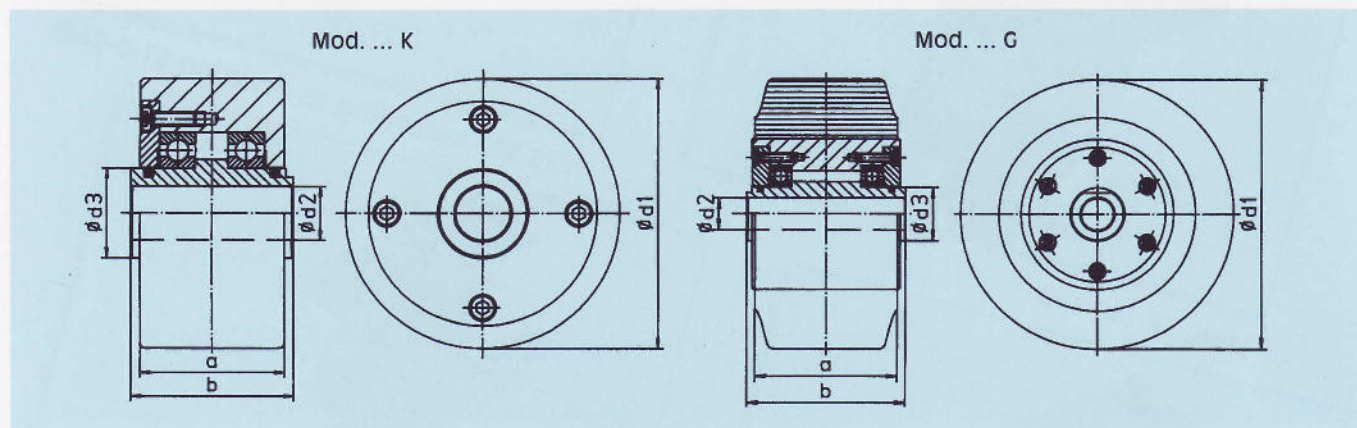

Model K, G

Mod.		a	b	Ø d1	Ø d2	Ø d3	Suitable castors			Carrying capacity (kN)		Weight (kg)	
Plastic	Rubber						SF	SL	SD	K	G	K	G
150 K		80	90	150	30	50	SF	SL	SD	20		3.7	
175 K		80	90	175	30	50	SF	SL	SD	20		4.3	
200 K		80	90	200	30	50	SF	SL	SD	30		5.0	
225 K		80	90	225	30	50	SF		SD	30		5.8	
250 K		80	90	250	30	50	SF		SD	35		6.7	
	250 G	130	145	250	30	50	SF		SD		10		9.0
	265 G	160	175	265	30	50	SF		SD		15		10.0
275 K		80	90	275	30	50	SF		SD	35		7.6	
300 K		80	90	300	30	50	SF			35		8.7	