

Heavy Duty Wheels

Model SF ... S, K, S/P

■ Fixed castors - Drawing No. R5

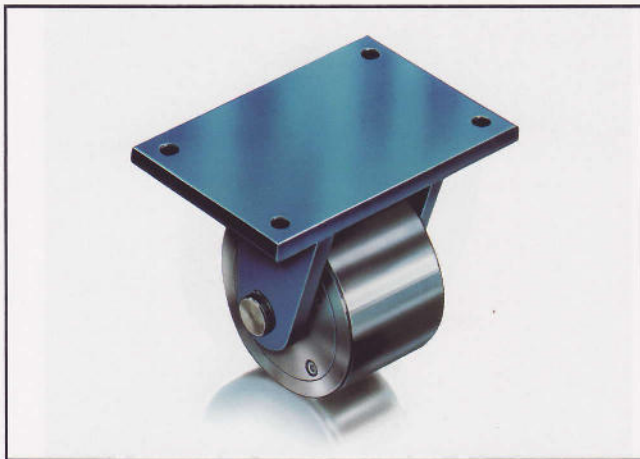

Range of application:

- For transporting loads at a maximum speed of 100 m/min.
- Flange wheels for use on profiles (see drawing No. R8).

Characteristics of the model ...SF ... S, K, S/P:

- Solid steel construction of the fixed castor.
- Position of fixing holes in top plate can be arranged to suit customers' requirement.
- Can be combined with other castors.
- Passed the DIN 4422 test at the material research laboratory for SF 150 S + SF 150 K.

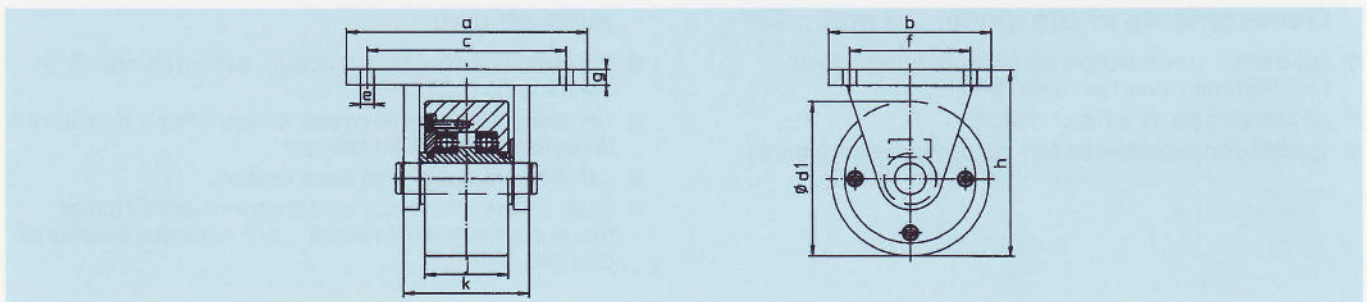

Model SF ... S, SF ... K

Mod.		a	b	c	∅ d1	∅ e	f	g	h	j	k	Suitable castors		Carrying capacity (kN)		Weight (kg)	
Steel	Plastic											SL	SD	S	K	S	K
SF 150 S	SF 150 K	220	150	190	150	14	115	15	180	80	120	SL	SD	30	20	16.7	10.7
SF 175 S	SF 175 K	220	150	190	175	14	115	15	210	80	120	SL	SD	30	20	21.4	12.1
SF 200 S	SF 200 K	220	150	190	200	14	115	15	235	80	120	SL	SD	30	30	26.7	13.6
SF 225 S	SF 225 K	220	150	190	225	14	115	15	260	80	120			30	30	32.7	15.2
SF 250 S	SF 250 K	270	210	210	250	18	150	15	285	80	120			35	35	41.9	19.3
SF 275 S	SF 275 K	270	210	210	275	18	150	15	310	80	120			35	35	49.7	21.0
SF 300 S	SF 300 K	270	210	210	300	18	150	15	335	80	120			35	35	58.6	22.9

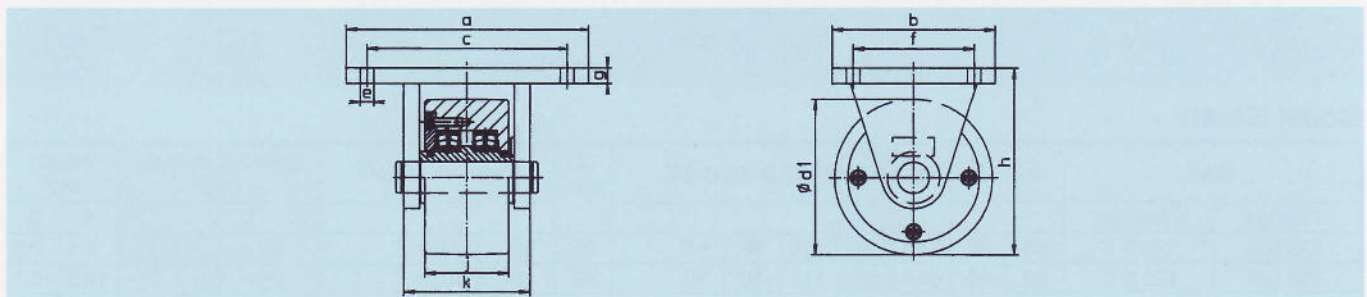

Model SF ... S/P

Mod.		a	b	c	∅ d1	∅ e	f	g	h	j	k	Suitable castors		Carrying capacity (kN)		Weight (kg)	
Steel												SL	SD				
SF 150 S/P		220	170	180	150	18	130	20	195	80	130	SL	SD	50			16.9
SF 175 S/P		220	170	180	175	18	130	20	220	80	130	SL	SD	50			21.6
SF 200 S/P		220	170	180	200	18	130	20	245	80	130	SL	SD	60			26.9
SF 225 S/P		220	170	180	225	18	130	20	285	80	130			60			32.9
SF 250 S/P		270	210	210	250	18	160	20	310	80	130			80			42.1
SF 275 S/P		270	210	210	275	18	160	20	320	80	130			80			49.9
SF 300 S/P		270	210	210	300	18	160	20	345	80	130			80			58.8