



PROFESSIONAL TORQUE WRENCHES



Since its original, award winning launch in 1984 and extensive face-lift in 2000, Norbar's Professional torque wrench range has become one of the most popular wrench ranges available worldwide. In this re-engineered version, the core principles of accuracy, durability and comfort are carried over but almost every component part is new and improved.



- Accurate to $\pm 3\%$ of reading which meets the requirements of ISO 6789-2:2017
- Supplied with a traceable 'Calibration Certificate' allowing end users to adhere to more stringent quality control processes

- Large scale for better visibility and more accurate setting
- Fast scale adjustment reducing the effort required to adjust. If you adjust your wrench regularly, you can do more work



Compared with other torque wrenches:

Norbar's 'harmonic drive' scale provides a long scale length for good resolution and accurate setting in both scale units. By contrast, micrometer type scales allow accurate setting in the primary scale unit but relatively poor accuracy of setting in the secondary units because of limited resolution. The Professional wrench is amongst the easiest wrenches on the market to accurately set.

Timestrip® Feature

Torque wrenches should be calibrated once a year as a minimum, more frequently in harsh environments and with high levels of usage. Norbar's Timestrip® gives a visual indication that the wrench is due for re-calibration and has 3, 6, 9 and 12 month graduations. (Timestrip® is a registered trademark of Timestrip UK Ltd).



Unlocked



Locked



Automotive Ratchet



Industrial Ratchet



Timestrip®



Professional Scale



Female Torque Handle



16 mm Spigot End



PROFESSIONAL TORQUE WRENCHES



'Mushroom' Square Drive

2 INDUSTRIAL RATCHET ('Mushroom' Head) - DUAL SCALE

15002*	Pro 50, 3/8", 10 - 50 N·m, 7.5 - 37.5 lbf·ft
15003	Pro 100, 1/2", 20 - 100 N·m, 15 - 75 lbf·ft
15004	Pro 200, 1/2", 40 - 200 N·m, 30 - 150 lbf·ft
15005	Pro 300, 1/2", 60 - 300 N·m, 44 - 222 lbf·ft
15006	Pro 340, 1/2", 60 - 340 N·m, 44 - 250 lbf·ft
15007*	Pro 400, 3/4", 80 - 400 N·m, 60 - 300 lbf·ft

2 INDUSTRIAL RATCHET ('Mushroom' Head) - N·m ONLY

15042*	Pro 50, 3/8", 10 - 50 N·m
15043	Pro 100, 1/2", 20 - 100 N·m
15044	Pro 200, 1/2", 40 - 200 N·m
15045	Pro 300, 1/2", 60 - 300 N·m
15046	Pro 340, 1/2", 60 - 340 N·m
15047*	Pro 400, 3/4", 80 - 400 N·m

2 INDUSTRIAL RATCHET ('Mushroom' Head) - lbf·ft ONLY

15172*	Pro 50, 3/8", 7.5 - 37.5 lbf·ft
15173	Pro 100, 1/2", 15 - 75 lbf·ft
15174	Pro 200, 1/2", 30 - 150 lbf·ft
15175	Pro 300, 1/2", 44 - 220 lbf·ft
15176	Pro 340, 1/2", 44 - 250 lbf·ft
15177*	Pro 400, 3/4", 60 - 300 lbf·ft

2 INDUSTRIAL RATCHET ('Mushroom' Head) - lbf·in ONLY

15052*	Pro 50, 3/8", 90 - 440 lbf·in
15053	Pro 100, 1/2", 200 - 900 lbf·in
15054	Pro 200, 1/2", 400 - 1,800 lbf·in
15055	Pro 300, 1/2", 500 - 2,500 lbf·in
15056	Pro 340, 1/2", 500 - 3,000 lbf·in
15057*	Pro 400, 3/4", 700 - 3,500 lbf·in

* Supplied with 1/2" sq. dr. adaptor

· Supplied with 3/8" sq. dr. adaptor

* Model 400 supplied with a Stepped Square

2 AUTOMOTIVE RATCHET (Reversible) - DUAL SCALE

15008	Pro 15, 1/4", 3 - 15 N·m, 27 - 132 lbf·in
15009	Pro 15, 3/8", 3 - 15 N·m, 27 - 132 lbf·in
15010	Pro 25, 1/4", 5 - 25 N·m, 44 - 220 lbf·in
15011	Pro 25, 3/8", 5 - 25 N·m, 44 - 220 lbf·in
15012	Pro 50, 3/8", 10 - 50 N·m, 7.5 - 37.5 lbf·ft
15013	Pro 50, 1/2", 10 - 50 N·m, 7.5 - 37.5 lbf·ft
15014	Pro 100, 3/8", 20 - 100 N·m, 15 - 75 lbf·ft
15015	Pro 100, 1/2", 20 - 100 N·m, 15 - 75 lbf·ft
15016	Pro 200, 1/2", 40 - 200 N·m, 30 - 150 lbf·ft

2 AUTOMOTIVE RATCHET (Reversible) - N·m ONLY

15018	Pro 15, 1/4", 3 - 15 N·m
15019	Pro 15, 3/8", 3 - 15 N·m
15020	Pro 25, 1/4", 5 - 25 N·m
15021	Pro 25, 3/8", 5 - 25 N·m
15022	Pro 50, 3/8", 10 - 50 N·m
15023	Pro 50, 1/2", 10 - 50 N·m
15024	Pro 100, 3/8", 20 - 100 N·m
15025	Pro 100, 1/2", 20 - 100 N·m
15026	Pro 200, 1/2", 40 - 200 N·m

2 AUTOMOTIVE RATCHET (Reversible) - lbf·ft ONLY

15142	Pro 50, 3/8", 7.5 - 37.5 lbf·ft
15143	Pro 50, 1/2", 7.5 - 37.5 lbf·ft
15144	Pro 100, 3/8", 15 - 75 lbf·ft
15145	Pro 100, 1/2", 15 - 75 lbf·ft
15146	Pro 200, 1/2", 30 - 150 lbf·ft

2 AUTOMOTIVE RATCHET (Reversible) - lbf·in ONLY

15028	Pro 15, 1/4", 27 - 132 lbf·in
15029	Pro 15, 3/8", 27 - 132 lbf·in
15030	Pro 25, 1/4", 44 - 220 lbf·in
15031	Pro 25, 3/8", 44 - 220 lbf·in
15032	Pro 50, 3/8", 90 - 440 lbf·in
15033	Pro 50, 1/2", 90 - 440 lbf·in
15034	Pro 100, 3/8", 200 - 900 lbf·in
15035	Pro 100, 1/2", 200 - 900 lbf·in
15036	Pro 200, 1/2", 400 - 1,800 lbf·in



PROFESSIONAL TORQUE WRENCHES



2 TORQUE HANDLE ADJUSTABLE 16 mm SPIGOT - DUAL SCALE

15060	Pro 15, 16 mm spigot, 3 - 15 N·m, 27 - 132 lbf-in
15061	Pro 25, 16 mm spigot, 5 - 25 N·m, 44 - 220 lbf-in
15062	Pro 50, 16 mm spigot, 10 - 50 N·m, 7.5 - 37.5 lbf-ft
15063	Pro 100, 16 mm spigot, 20 - 100 N·m, 15 - 75 lbf-ft
15064	Pro 200, 16 mm spigot, 40 - 200 N·m, 30 - 150 lbf-ft
15065	Pro 300, 16 mm spigot, 60 - 300 N·m, 44 - 222 lbf-ft

2 TORQUE HANDLE ADJUSTABLE 16 mm SPIGOT - N·m ONLY

15070	Pro 15, 16 mm spigot, 3 - 15 N·m
15071	Pro 25, 16 mm spigot, 5 - 25 N·m
15072	Pro 50, 16 mm spigot, 10 - 50 N·m
15073	Pro 100, 16 mm spigot, 20 - 100 N·m
15074	Pro 200, 16 mm spigot, 40 - 200 N·m
15075	Pro 300, 16 mm spigot, 60 - 300 N·m

2 TORQUE HANDLE ADJUSTABLE 16 mm SPIGOT - lbf-ft ONLY

15082	Pro 50, 16 mm spigot, 7.5 - 37.5 lbf-ft
15083	Pro 100, 16 mm spigot, 15 - 75 lbf-ft
15084	Pro 200, 16 mm spigot, 30 - 150 lbf-ft
15085	Pro 300, 16 mm spigot, 44 - 220 lbf-ft

2 TORQUE HANDLE ADJUSTABLE 16 mm SPIGOT - lbf-in ONLY

15090	Pro 15, 16 mm spigot, 27 - 132 lbf-in
15091	Pro 25, 16 mm spigot, 44 - 220 lbf-in
15092	Pro 50, 16 mm spigot, 90 - 440 lbf-in
15093	Pro 100, 16 mm spigot, 200 - 900 lbf-in
15094	Pro 200, 16 mm spigot, 400 - 1,800 lbf-in
15095	Pro 300, 16 mm spigot, 500 - 2,500 lbf-in



2 FEMALE TORQUE HANDLE ADJUSTABLE - DUAL SCALE

15100	Pro 15, 9 x 12 mm, 3 - 15 N·m, 27 - 132 lbf-in
15101	Pro 25, 9 x 12 mm, 5 - 25 N·m, 44 - 220 lbf-in
15102	Pro 50, 9 x 12 mm, 10 - 50 N·m, 7.5 - 37.5 lbf-ft
15103	Pro 100, 9 x 12 mm, 20 - 100 N·m, 15 - 75 lbf-ft
15104	Pro 200, 9 x 12 mm, 40 - 200 N·m, 30 - 150 lbf-ft
15105	Pro 200, 14 x 18 mm, 40 - 200 N·m, 30 - 150 lbf-ft
15106	Pro 300, 14 x 18 mm, 60 - 300 N·m, 44 - 222 lbf-ft
15107	Pro 340, 14 x 18 mm, 60 - 340 N·m, 44 - 250 lbf-ft
15108	Pro 400, 14 x 18 mm, 80 - 400 N·m, 60 - 300 lbf-ft

2 FEMALE TORQUE HANDLE ADJUSTABLE - N·m ONLY

15110	Pro 15, 9 x 12 mm, 3 - 15 N·m
15111	Pro 25, 9 x 12 mm, 5 - 25 N·m
15112	Pro 50, 9 x 12 mm, 10 - 50 N·m
15113	Pro 100, 9 x 12 mm, 20 - 100 N·m
15114	Pro 200, 9 x 12 mm, 40 - 200 N·m
15115	Pro 200, 14 x 18 mm, 40 - 200 N·m
15116	Pro 300, 14 x 18 mm, 60 - 300 N·m
15117	Pro 340, 14 x 18 mm, 60 - 340 N·m
15118	Pro 400, 14 x 18 mm, 80 - 400 N·m

2 FEMALE TORQUE HANDLE ADJUSTABLE - lbf-ft ONLY

15122	Pro 50, 9 x 12 mm, 7.5 - 37.5 lbf-ft
15123	Pro 100, 9 x 12 mm, 15 - 75 lbf-ft
15124	Pro 200, 9 x 12 mm, 30 - 150 lbf-ft
15125	Pro 200, 14 x 18 mm, 30 - 150 lbf-ft
15126	Pro 300, 14 x 18 mm, 44 - 220 lbf-ft
15127	Pro 340, 14 x 18 mm, 44 - 250 lbf-ft
15128	Pro 400, 14 x 18 mm, 60 - 300 lbf-ft

2 FEMALE TORQUE HANDLE ADJUSTABLE - lbf-in ONLY

15130	Pro 15, 9 x 12 mm, 27 - 132 lbf-in
15131	Pro 25, 9 x 12 mm, 44 - 220 lbf-in
15132	Pro 50, 9 x 12 mm, 90 - 440 lbf-in
15133	Pro 100, 9 x 12 mm, 200 - 900 lbf-in
15134	Pro 200, 9 x 12 mm, 400 - 1,800 lbf-in
15135	Pro 200, 14 x 18 mm, 400 - 1,800 lbf-in
15136	Pro 300, 14 x 18 mm, 500 - 2,500 lbf-in
15137	Pro 340, 14 x 18 mm, 500 - 3,000 lbf-in
15138	Pro 400, 14 x 18 mm, 700 - 3,500 lbf-in



PROFESSIONAL TORQUE WRENCHES



Industrial Ratchet

Model	Pro 50	Pro 100	Pro 200	Pro 300	Pro 340	Pro 400	
Part Number	15002	15003	15004	15005	15006	15007	
	15042	15043	15044	15045	15046	15047	
	15172	15173	15174	15175	15176	15177	
	15052	15053	15054	15055	15056	15057	
Dimensions (mm)	A	335	387	470	593	685	686
	B	317	364	447	567	659	661
	C	231	278	361	480	572	574
	∅D	35	45	45	52	52	51
	E	37	48	48	48	48	47
	F	26	32	32	33	33	24
Weight (kg)	0.7	0.9	1.1	1.4	1.5	1.9	

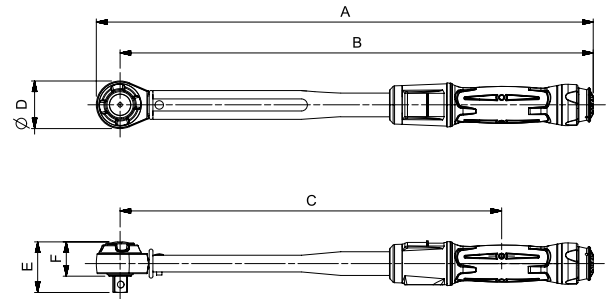

Automotive Ratchet

Model	Pro 15 Pro 25	Pro 50 3/8"	Pro 50 1/2"	Pro 100 3/4"	Pro 100 1/2"	Pro 200	
Part Number	15008, 15009, 15010, 15011, 15018, 15019, 15020, 15021, 15028, 15029, 15030, 15031	15012 15022 15142 15032	15013 15023 15143 15033	15014 15024 15144 15034	15015 15025 15145 15035	15016 15026 15146 15036	
	A	221	327	327	367	367	465
	B	209	312	312	352	352	444
	C	140	226	226	266	266	358
Dimensions (mm)	∅D	25	30	30	30	30	43
	E	25	33	38	33	38	46
	F	18	22	22	22	22	30
	Weight (kg)	0.3	0.7	0.7	0.8	0.8	1.0

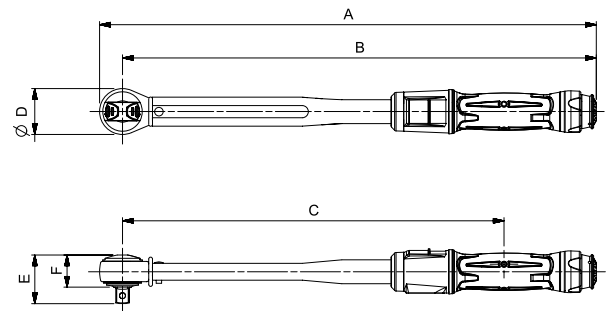

Spigot Torque Handle

Model	Pro 15 Pro 25	Pro 50	Pro 100	Pro 200	Pro 300	
Part Number	15060 15061 15070 15071 15090 15091	15062 15072 15082 15092	15063 15073 15083 15093	15064 15074 15084 15094	15065 15075 15085 15095	
	A	223	322	363	445	569
	B	216	316	356	438	563
	C	148	229	269	351	476
	∅D	16	16	16	16	16
	Weight (kg)	0.3	0.6	0.7	0.9	1.2

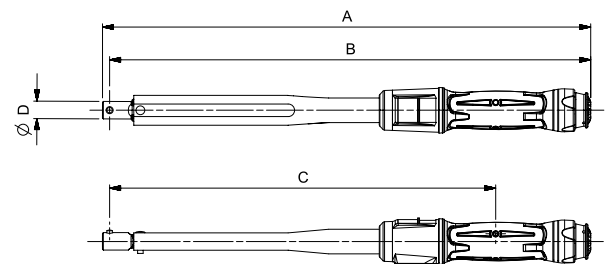

Female Torque Handle

Model	Pro 15 Pro 25	Pro 50	Pro 100	Pro 200 9 x 12 mm	Pro 200 14 x 18 mm	Pro 300	Pro 340	Pro 400	
Part Number	15100 15101 15110 15111 15112 15122 15130 15131	15102 15112 15122 15132	15103 15113 15123 15133	15104 15114 15124 15134	15105 15115 15125 15135	15106 15116 15126 15136	15107 15117 15127 15137	15108 15118 15128 15138	
	A	218	325	365	442	453	570	662	664
	B	204	314	354	431	440	557	649	649
	C	139	227	267	345	353	440	562	563
	D	22	22	22	25	34	34	34	32
	E	20	20	20	20	26	28	28	24
	Weight (kg)	0.3	0.6	0.7	0.9	1.0	1.2	1.3	1.7

