

This 'Original instructions' document assumes that the operator carrying out any operation with this product is trained and competent to do so. This manual does not attempt to cover all details or variations in the equipment. Nor does this manual claim to provide for every possible contingency met in connection with the installation, operation, or maintenance thereof. Should further information be desired, or should a particular problem arise which is not covered in sufficient detail, the matter should be referred to Hi-Force.

## OPERATING INSTRUCTION MANUAL

### ATDP – Air driven, twin, double acting hydrotest pumps

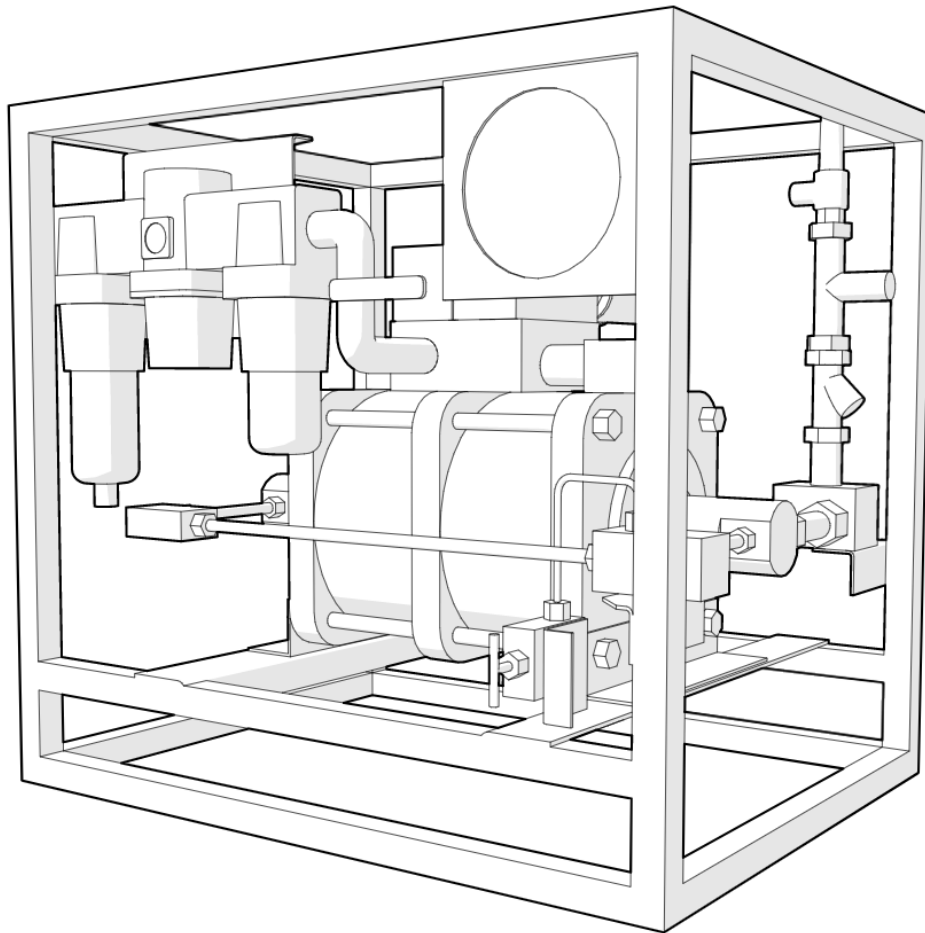

This manual applies to the Hi-Force ATDP series of air driven hydrotest pumps only. It contains the latest product information available at the time of publication and approval. For information relating to the servicing of an ATDP pump, see the servicing instructions, which are available on the Hi-Force website. Hi-Force reserves the right to make changes to this document at any time without notice.

**Table of contents**

**1.0 Specifications**.....Page 3

**2.0 System Components/Accessories**.....Page 4

**3.0 Inspection upon receipt**.....Page 4

**4.0 Safety Precautions**.....Page 4

    4.1 Introduction.....Page 4

    4.2 Work area safety.....Page 5

    4.3 General precautions.....Page 5

    4.4 ATDP Specific safety precautions.....Page 7

**5.0 Declaration of conformity**.....Page 7

**6.0 General description**.....Page 8

**7.0 Component identification**.....Page 9

**8.0 Installation / Setup**.....Page 10

    8.1 Before first use.....Page 10

    8.2 Operation.....Page 11

**9.0 Maintenance / Storage**.....Page 12

**10.0 Trouble shooting**.....Page 13

**11.0 Contact details**.....Page 14

**NOTE:** Images contained within this document are for illustrative purposes **ONLY**.

## 1.0 Specifications

### Max air consumption:

6 m<sup>3</sup> (212scfm) at 7 bar.

A minimum supply pipe bore of ½” diameter is required to allow the pump to operate correctly.

### Fluid inlet port:

1” BSP (All models)

### Outlet Port:

ATDP63 = ½” NPT

ATDP125 = ½” NPT

ATDP216 = 1.1/8” -12 UNF

### Pump operating temperatures:

-20c to +50c

### Noise level:

An average A-Weighted sound pressure level of 75dB was measured for undefined workspaces, as per Directive 2006/42/EC Section 1.7.4.2 (u).

### Recommended Fluids:

- De-ironised / De-mineralised water.
- Water Glycol
- Hydraulic oil (see chart below)

Hi-Force tools use 2 grades of hydraulic oil, dependant on the tool.

ISO Hydraulic oil grade	Temperature range Degrees Celcius	
	From:	To:
ISO15	-23	44
ISO46	-2	73

**IMPORTANT:** If in doubt about the suitability of the operating fluid you intend to use, please consult your nearest Hi-Force office or distributor. Use of unsuitable operating fluids **WILL** void your warranty.

## ATDP Models

Refer to name plate on the pump for identification.

Model number	Max output pressure (bar) at airline input pressure			Fluid volume displacement per stroke (cm <sup>3</sup> )	Outlet port thread	Weight (kg)
	20 psi 1.38 bar	60 psi 4.14 bar	100 psi 6.9 bar			
ATDP63	87	260	434	275	½" NPT	96
ATDP125	172	517	862	140	½" NPT	96
ATDP216	298	894	1489	79	1 ½"-12 UNF	96

## 2.0 System Components/Accessories

*(Refer to the Hi-Force website or latest Hi-Force catalogue, for further details)*

- Stroke counter system.
- Chart recorder (including spare pens and charts).
- Isolation section for chemical duty.

## 3.0 Inspection upon Receipt

Upon receipt of the product, visually inspect the item for any evidence of shipping damage. Please note: the warranty does not cover shipping damage. Notify the courier immediately if shipping damage is found and refrain from putting the product into service. The carrier is responsible for repair and replacement costs resulting from damage that occurred in transit.

## 4.0 Safety Precautions

### 4.1 Introduction



Read and follow all the instructions and safety warnings carefully before handling, installation or use of any hydraulic equipment. Failure to do so could lead to equipment damage, equipment failure, personal injury or even death. Hi-Force will not be held responsible for any damage to the equipment, injury or death resulting from the unsafe use of, lack of maintenance to, or incorrect operation of the product. If in doubt on the correct use of any Hi-Force equipment, contact your nearest Hi-Force office or distributor. Only qualified personnel should be allowed to operate hydraulic equipment. If an operator has not been trained on high-pressure hydraulic equipment and its safe usage, consult your local Hi-Force sales office or distributor who can offer training courses for operators.

## 4.2 Work Area Safety

- Keep work areas clean and well lit. Cluttered spaces and inadequate lighting can result in unnecessary accidents.
- Keep bystanders clear of any hydraulic tool activity. Personnel working in close-range should be made aware of all high-pressure work before commencing.

## 4.3 General Precautions



**WARNING!** Failure to observe and obey the following safety precautions could result in property damage, significant personal injury or death;



- When operating any hydraulic equipment, all operators should ensure that all necessary personal protective equipment (PPE) is worn, as specified by their employer. Steel toe-cap safety shoes, safety glasses/visor, and protective gloves should be worn at all times. All relevant risk assessments should be completed before the use of the equipment.
- Keep hydraulic equipment away from open flames and direct heat.
- **NEVER** handle a pressurised hydraulic hose. Hydraulic fluid escaping under pressure from a ruptured hose can penetrate the skin and lead to a significant medical emergency, and in some cases, death. Should this incident occur, seek out medical attention immediately.
- Seek medical attention immediately if a hydraulic injection injury (no matter how minor) occurs.
- The system operating pressure **MUST NOT** exceed the pressure rating of the lowest-rated component in the system.
- Only use hydraulic tools/cylinders in a complete and tested, coupled system. **NEVER** attempt to use a tool/cylinder that is not correctly coupled to its operational pump. **NEVER** pressurise uncoupled male couplers.
- **NEVER** attempt to disconnect a hose from a hydraulic system until the system's pressure has been completely released. Doing so can result in that pressure becoming trapped within the system and relieving trapped pressure can be dangerous.
- Loosening a hydraulic fitting under pressure can result in the escape of hydraulic fluid at high pressure, which can penetrate the skin and cause significant injury or death.
- **NEVER** attempt to solve, or clean-up leaks in the system while the system is pressurised.
- Immediately replace any worn or damaged parts using genuine Hi-Force parts only.
- **DO NOT** use any hydraulic equipment if you are under the influence of alcohol, drugs or medication. Lack of attention whilst operating high-pressure hydraulic tools can result in personal injury or death.



## CAUTION!

Failure to observe and obey the following safety precautions could result in property damage, equipment damage or minor/moderate personal injury;

- **NEVER** lift, carry or move any hydraulic components by the hose or hoses connected to them.
- Avoid damaging hydraulic hoses. **ALWAYS** route hoses to ensure that they are free from sharp bends and kinks. Using a sharply bent or kinked hose will result in severe back-pressure, which can lead to hose failure.
- **NEVER** use a coupler/s to lift, carry or position a tool.
- Servicing of hydraulic equipment must only be undertaken by a qualified technician.

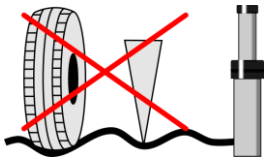

- **DO NOT** drop or place heavy objects on a hydraulic hose, as this may cause internal damage, which could result in rupture of the pressurised hose. A ruptured hose could cause significant damage to components and possible severe injury to personal operating nearby.

- **DO NOT** let familiarity gained with any hydraulic tools allow you to become complacent. Complacency with any tooling can result in a lack of discipline toward working guidelines and safety principles.
- **DO NOT** remove any labels from the product. Replace any damaged or unreadable labels immediately.
- Avoid loose clothing and jewellery that could get caught in moving parts, tie back long hair.

#### 4.4 ATDP Specific Safety Precautions



**WARNING!** Failure to observe and obey the following safety precautions could result in property damage, serious personal injury or death;

- **NEVER** exceed the maximum rated pressure or load capacity of any hydraulic pump. Hi-Force manufactures its ATPD range of hydrotest pumps to operate at a maximum working pressure of 1489bar (21,596 psi). **See Specifications**
- **DO NOT** adjust or remove the external pressure/air relief valve (ARV) on any Hi-Force product.
- **NEVER** invert the unit or lay it on its side, either in use, in transport or in storage.
- **DO NOT** weld any items to the unit or modify it in any way from its delivered condition. Your warranty may be invalidated, and it could lead to serious personal injury.
- **NEVER** exceed the maximum rated capacity of any hydraulic system component.
- Keep hands and feet away from the hydraulic system during operation.



**CAUTION!** Failure to observe and obey the following safety precautions could result in property damage, equipment damage or minor/moderate personal injury;

- To protect your warranty, only use the fluids specified in **Section 1.0**.
- When moving the unit, make sure all power cables and hoses are kept clear of the pump to avoid damage.

#### 5.0 Declaration of Incorporation/Conformity

Hi-Force declares that this product has been tested and complies with the standards and declarations as set out in the Declaration of Incorporation/Conformity (DoI/DoC). The DoI/DoC is included as Annex A to this instruction document and is supplied with all shipments of this product.

## 6.0 General Description

Hi Force ATDP Hydrotest pumps are designed to have an infinitely variable output pressure and displacement speed. They are fitted with an integral filtration and lubrication unit and air pressure gauge. An airline regulator allows for easy setting of air inlet pressure and output hydraulic pressure. The air start/stop valve allows for easy and fast pressure shut off. An air relief valve (ARV) is fitted to the air inlet. The ARV is factory set to allow maximum pressure to be achieved and vent any overpressurisation to the atmosphere.

The Hi-Force ADTP range of Hydrotest pumps are supplied in a range of 3 models with output pressures ranging from 87 bar(1260psi) to 1489bar (21596psi) and are suitable for use with various fluids. **See 1.0 Specifications.**

The ADTP air driven liquid pump range work on an automatic reciprocating differential area piston principle that uses large area air drive pistons connected to smaller area hydraulic pistons to convert compressed air power into hydraulic power.

The ADTP pump range has a double acting motion incorporating two hydraulic cylinder and piston assemblies, as liquid is introduced into one hydraulic cylinder on the pump suction stroke, liquid is automatically delivered from the second high pressure cylinder at the same time on the pump delivery stroke and vice versa. When the pump reaches the end of its stroke the spool valve in the air change over valve motor automatically shifts, reversing the pump direction; hence delivery flow is relatively smooth with only a small interruption in flow (dwell) as the pump air pistons change direction.

The units consist of a robust framework, fitted with an air driven hydraulic pump and complete with all necessary hydraulic accessories i.e. a 150mm diameter hydraulic pressure gauge, a hydraulic pressure release valve and all interconnecting pipe-work fittings and adaptors, terminating at a single high pressure outlet connection port. Pneumatic accessories include an air filter, air pressure regulating valve, oil lubricator, air gauge, ARV and air on/off valve.

A fluid inlet connection is provided and a Y type fluid strainer and fluid relief valve set at approximately 10 bar is fitted between this connection and the pump inlet check valves.

Provision is provided for fluid drainage via a nylon hose connected to the hydraulic pressure release valve.

The **ATDP63** has a maximum working pressure of 434Bar (6,295psi) on the hydraulic pressure circuit. The hydraulic pressure to be generated by the air driven pump is dependent upon the air pressure applied i.e. Pump ratio 63/1: 1psig air drive pressure applied can generate 63psig hydraulic pressure.

The **ATDP125** has a maximum working pressure of 862Bar (12502psi) on the hydraulic pressure circuit. The hydraulic pressure to be generated by the air driven pump is dependent upon the air pressure applied i.e. Pump ratio 125/1: 1psig air drive pressure applied can generate 125psig hydraulic pressure.

The **ATDP216** has a maximum working pressure of 1489Bar (21596psi) on the hydraulic pressure circuit. The hydraulic pressure to be generated by the air driven pump is dependent



upon the air pressure applied i.e. Pump ratio 216/1: 1psig air drive pressure applied can generate 216psig hydraulic pressure.

## 7.0 Component Identification

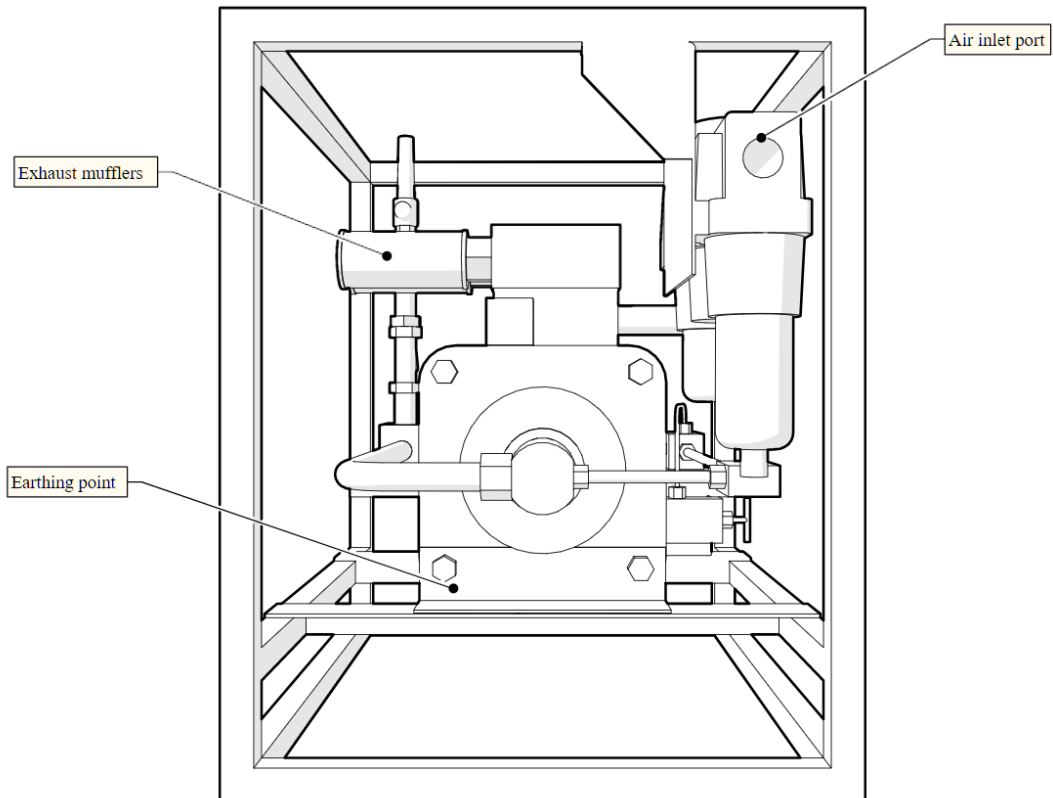
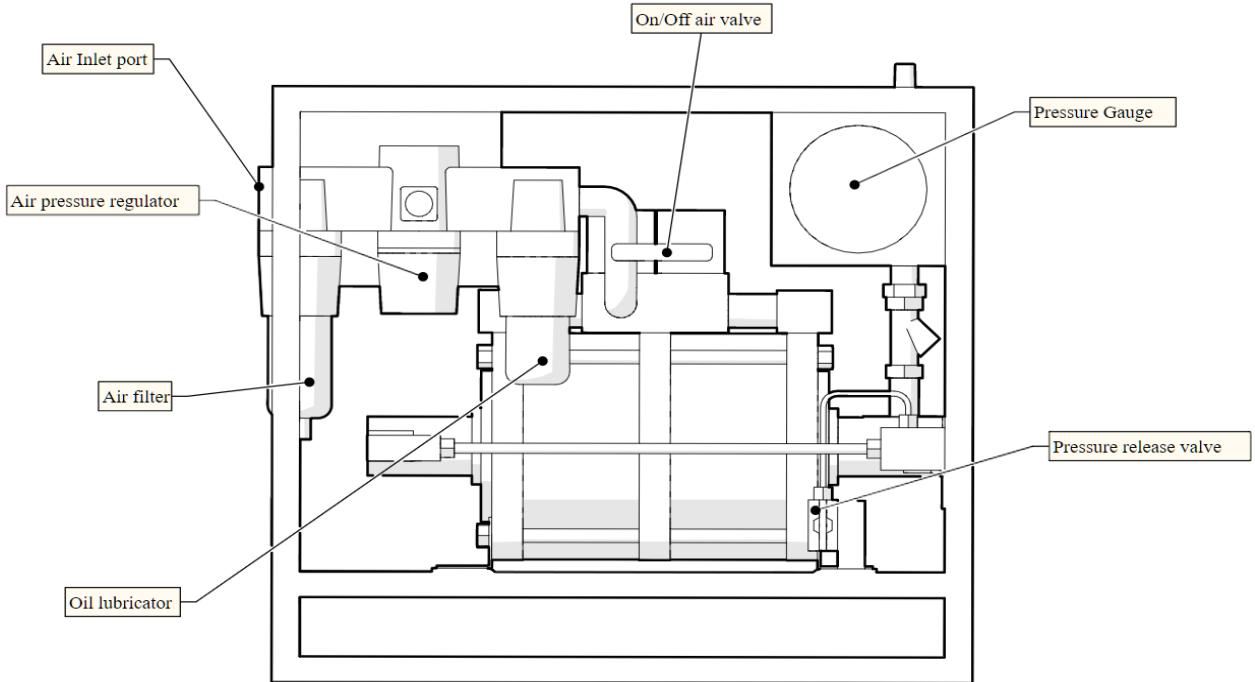

## 8.0 Installation/Setup

### 8.1 Before First Use / Preparation

It is recommended to use good quality clean & dry air (without moisture content) to drive the air driven pump unit. As the air pressure drops at the pump exhaust ports, the air will cool and any water droplets in the air can freeze prematurely due to temperature variation. For this reason we recommend the use of Anti Freeze Pneumatic Tool Lubricant such as 'Kilfrost K400' at all times. This is to be placed in the oil lubrication bottle. The lubricator bottle drip feed rate is advised at 1 drop per 20 pump strokes. (Please note: Hi-Force do not supply anti-freeze lubricant, as this is the responsibility of the end user.)

If for any reason the lubricator is not used, the air motor should be disassembled, inspected and repacked with suitable compound grease every 1 million strokes. Silicone type grease is prone to stiffening when not in use, at a minimum the grease should be changed after a 6month idle period and every 12 months in a scheduled routine service interval at a minimum.

Connect the hydraulic pressure outlet port to the equipment to be pressurised via a flexible hose assembly or via a rigid pipe-work system. Ensure that all attached hose, pipe-work and fittings are rated suitably to match, at a minimum, or exceed the maximum working pressure rating of the pump unit.

Direct the provided drain hose into a suitable container or drain.

Connect an air supply hose of at least ½" bore, to the power pack air inlet port. Use appropriately pressure rated air hose and fittings for this purpose, these components must be rated at a higher working pressure than the maximum supply air pressure that can be applied to the power pack. (½" bore air supply tubing is the smallest size that will allow the pump to operate).

Ensure that the air on/off valve on the pump is in the closed before switching on the air supply. (Note: To achieve the potential maximum working pressure and output flow capability, ensure an air supply of 7 bar (100psi) is available with a flow rate of 212 SCFM (6m<sup>3</sup>/min). The use of a smaller bore air hose or a smaller SCFM volume supply is acceptable but will diminish the maximum potential flow-rate from the pump.

Make connections to the fluid inlet port using suitably rated hose, pipe-work and fittings and a fluid isolation valve. The fluid inlet hose and fittings bore is recommended to be not less than 1" bore.

Once the pump has raised hydraulic pressure DO NOT close the fluid inlet isolation valve.

Ensure the water supply is sufficient and only at 7 bar maximum pressure. It is advisable to ensure clean water (fluid) is used as this prevents any possible chance of debris contaminating the pump check valves (Y type strainer filter built in pump unit water line).

If fluid is being supplied from a tank ensure the tank is sited close to the fluid inlet port on the power pack or sited above the level of the fluid inlet port (positive head/displacement pump).

Reducing the fluid supply inlet hose/pipe bore or supplying water from a tank at a lower level than the pump inlet port may cause pump cavitation's and potential damage, so should always be avoided.

**IMPORTANT:** Running the pump dry will result in damage.

## **8.2 Operation**

- 1) Check that the pump on/off air valve is closed, and that the hydraulic pressure release valve is in the open position.
- 2) Adjust the pump air pressure-regulating valve anticlockwise until it is fully wound out. Switch on the air supply to the pump by external means.
- 3) Plug the hydraulic outlet connection.
- 4) Turn on the water supply to the pump. As long as the water supply is above approximately 0.7bar (10 psi) the water will flow through the pump and through the drain hose attached to the pressure release valve, bleeding the system. If not (flowing water) turn the pump air pressure regulating valve slowly clockwise until 15-20 psi is shown on the air pressure regulators own air pressure gauge, the pump will operate pumping the inlet water supply to drain.
- 5) Turn the pump air on/off valve to the off position and close the hydraulic pressure release valve once any air bubbles, seen in the nylon drain hose, have disappeared and the system is bled properly.
- 6) To use the pump:
  - Open the pump air on/off valve.
  - Slowly adjust the pump air pressure-regulating valve clockwise, the pump will reciprocate and start to displace fluid into the system and build up pressure, the pressure generated can be viewed on the hydraulic pressure gauge.
  - The maximum pressure achievable at various air pressures can be seen in the Hi-Force catalogue ATDP page under the heading "Max output pressure at airline input pressure" e.g. ATDP63 if 80 psi air pressure is applied then the maximum pressure the pump can generate is approximately 80psi x the pump ratio 63/1 = 5,040psi (347bar). ATDP125 if 80 psi air pressure is applied then the maximum pressure the pump can generate is approximately 80psi x the pump ratio 125/1 = 10,000psi (700bar). ATDP216 if 80 psi air pressure is applied then the maximum pressure the pump can generate is approximately 80psi x the pump ratio 216/1 = 17280psi (1191bar).
  - If a slower pump cycle rate is required the drive air pressure can be reduced by turning the air pressure regulating valve anticlockwise and/or by partially closing the pump air on /off valve
  - The pump can operate as a transfer pump filling the vessel under test with liquid.
  - The pump will gradually and naturally start to cycle at a slower rate as the pressure in the vessel under test increases until it stops (stalls) when a balance of forces is reached i.e. when the air drive pressure x air drive piston area = stall pressure x driven hydraulic piston area.
  - The pump will hold pressure indefinitely unless a leak occurs, at which time the pump will automatically cut in once the leak rate reaches a certain level to try to maintain the pressure in the system.

- If the air supply is turned to the OFF position the hydraulic pressure generated will hold on the pumps integral check valves (in small volume systems the hydraulic pressure may fall slightly and then stop whilst the check valve balls reseal, this is normal).

The pump will continuously stroke if the circuit is open (flushing mode). Close the air start/stop valve to stop the pump at any point, if required.

7) Once the test is completed to release hydraulic system pressure:

- Turn the air on/off valve to the off position
- Turn the air pressure- regulating valve anticlockwise until it fully is wound out.
- **Slowly** open the pressure release valve and fluid will return via the drain hose to drain until zero pressure is indicated on the pump hydraulic pressure gauge.

It is possible to pre-set the pump so it stalls automatically at the desired pressure. This can be done by plugging the pressure outlet port and operating the pump. Adjust the air pressure regulator gradually upwards such that the pump stalls at the correct pressure. Release the pressure by opening the pressure release valve. Close the pressure release valve once more to check the set pressure. Provided that no adjustments are made the pump will repeat this set pressure when connected to a pressure vessel.

## **9.0 Maintenance and Storage**

Carry out basic maintenance on a regular basis to keep the system operating in a trouble-free manner. Maintenance intervals are determined by the frequency of use of the system and the operating conditions on site.

- Keep the unit clean. Use a damp cloth to avoid any static build up.
- Silicone type grease is prone to stiffening when not in use, at a minimum the grease should be changed after a 6 month idle period and every 12 months in a scheduled routine service interval at a minimum.
- **ALWAYS** keep the unit upright in storage.

**IMPORTANT: ALWAYS** dispose of used fluids in a responsible manner, in accordance with local regulations.

## 10.0 Troubleshooting

Hi-Force ATDP pumps should be serviced and repaired only by authorised Hi-Force repair centres. The following table gives possible causes and solutions for common problems.

<b>TROUBLESHOOTING GUIDE</b>		
<b>Problem</b>	<b>Possible Cause</b>	<b>Solution</b>
1. Pump will not start. Or runs erratically.	a. Mufflers blocked or iced up.	I. Check mufflers. II. Check Anti-freeze lubricant level.
	b. Fluid supply starvation.	Check supply.
	c. Insufficient air supply,	Check supply lines and pressure.
	d. Insufficient lubrication.	I. Check lubrication level. II. Service pump.
	e. Pump is damaged, seized or worn.	Contact your local Hi-Force office / distributor.
2. Motor stalls before full operating pressure is reached.	a. Insufficient air supply.	Check supply lines and pressure.
3. Pump struggles to build pressure or maintain pressure under load.	a. Release valve incorrectly closed.	Check release valve.
	b. Valve is damaged, seized or worn	Contact your local Hi-Force office / distributor.
4. Overload protection valve leaking.	a. Air/hydraulics overloaded b. Faulty Valve.	I. Check pressures. II. Contact your local Hi-Force office / distributor.
5. Noisy Operation	a. Air trapped in the hydraulic system.	Bleed air from the system. (See section 5.3)
	b. Air leaking into the hydraulic system.	Visually inspect all areas where air might leak into the hydraulic system.
	c. Oil level too low.	Check unit for visible leaks. Add oil as per section 5.2.

**Head Office:**

Hi-Force Limited  
Prospect Way, Daventry  
Northamptonshire NN11 8PL  
United Kingdom  
Tel: + 44 1327 301000 | Fax: + 44 1327 706555  
[www.hi-force.com](http://www.hi-force.com)

**Regional Offices:**

For information on our offices worldwide, scan the below QR code

