

This 'original instructions' document assumes that the operator carrying out any operation with this product is trained and competent to do so. This manual does not attempt to cover all details or variations in the equipment. Nor does this manual claim to provide for every possible contingency met in connection with the installation, operation, or maintenance thereof. Should further information be desired, or should a particular problem arise which is not covered in sufficient detail, the matter should be referred to Hi-Force.

## OPERATING INSTRUCTION MANUAL

### HEP2 & HEP3 SERIES | ELECTRIC DRIVEN PUMPS

- HEP2 - GENERAL DUTY, MEDIUM FLOW
- HEP3 - GENERAL DUTY, HIGH FLOW

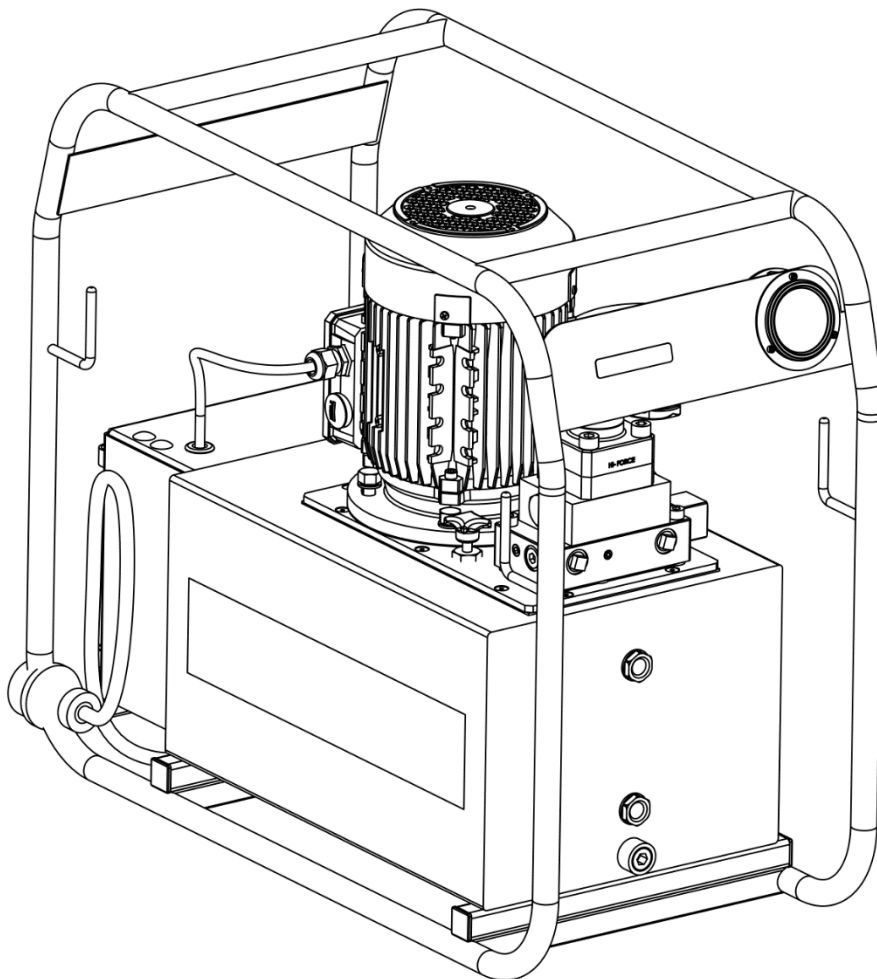

Hi-Force HEP2 and HEP3 series Electric Driven Hydraulic Pumps are designed to operate high pressure hydraulic cylinders and tools with a maximum working pressure of 700Bar. This manual applies to the Hi-Force HEP2 and HEP3 series, Electric Driven Hydraulic Pumps. It contains the latest product information available at the time of publication and approval. Hi-Force reserves the right to make changes to this document at any time without notice.

## Table of Contents

<b>1.0 Inspection upon Receipt.....</b>	<b>3</b>
<b>2.0 Safety Precautions .....</b>	<b>3</b>
2.1 Introduction .....	3
2.2 Work Area Safety.....	3
2.3 General Hydraulic System Safety Precautions.....	3
2.4 Hydraulic Pump Specific Safety Precautions .....	5
<b>3.0 Declaration of Incorporation / Conformity .....</b>	<b>5</b>
<b>4.0 Component Identification .....</b>	<b>6</b>
<b>5.0 Installation/Setup .....</b>	<b>8</b>
5.1 Before First Use.....	8
5.2 Filling the Pump with Oil.....	9
5.3 Electrical Connection .....	9
5.4 Hydraulic Connections.....	10
5.5 Bleeding Trapped Air from the System.....	10
<b>6.0 Operation .....</b>	<b>11</b>
6.1 Setting the Pressure Relief Valve.....	11
6.2 Pumps with Manual Valves .....	12
6.3 Pumps with Solenoid Valves .....	13
<b>7.0 Maintenance and Storage.....</b>	<b>13</b>
<b>8.0 Specifications .....</b>	<b>14</b>
8.1 HEP2 Specifications .....	14
8.2 HEP3 Specifications .....	15
8.3 HEP2 / HEP3 Pump Electrical Characteristics.....	15
<b>9.0 System Components / Accessories .....</b>	<b>16</b>
<b>10.0 Troubleshooting.....</b>	<b>17</b>

**NOTE:** Images contained within this document are for illustrative purposes **ONLY**.

## 1.0 Inspection upon Receipt

Upon receipt of the product, visually inspect the item for any evidence of shipping damage. Please note: the warranty does not cover shipping damage. Notify the courier immediately if shipping damage is found and refrain from putting the product into service. The carrier is responsible for repair and replacement costs resulting from damage that occurred in transit.

## 2.0 Safety Precautions

### 2.1 Introduction



Read and follow all the instructions and safety warnings carefully before handling, installation or use of any hydraulic equipment. Failure to do so could lead to equipment damage, equipment failure, personal injury or even death. Hi-Force will not be held responsible for any damage to the equipment, injury or death resulting from the unsafe use of, lack of maintenance to, or incorrect operation of the product. If in doubt on the correct use of any Hi-Force equipment, contact your nearest Hi-Force office or distributor. Only qualified personnel should be allowed to operate hydraulic equipment. If an operator has not been trained on high-pressure hydraulic equipment and its safe usage, consult your local Hi-Force sales office or distributor who can offer training courses for operators.

### 2.2 Work Area Safety

- Keep work areas clean and well lit. Cluttered spaces and inadequate lighting can result in unnecessary accidents.
- Keep unauthorised persons at a safe distance from the task site.
- **NEVER** use the tools in the presence of inflammable liquids, gases or material.
- **DO NOT** use the tools in potentially explosive atmospheres (ATEX) this tool is **NOT** ATEX approved.

### 2.3 General Hydraulic System Safety Precautions



**WARNING!** Failure to observe and obey the following safety precautions could result in property damage, significant personal injury or death;



- When operating any hydraulic equipment, all operators should ensure that all necessary personal protective equipment (PPE) is worn, as specified by their employer. Steel toe-cap safety shoes, safety glasses/visor, and protective gloves should be worn at all times. All relevant risk assessments should be completed before the use of the equipment.
- Keep hydraulic equipment away from open flames and direct heat.
- **NEVER** handle a pressurised hydraulic hose. Hydraulic oil escaping under pressure from a ruptured hose can penetrate the skin and lead to a significant medical emergency, and in some cases, death. Should this incident occur, seek out medical attention immediately.

- The system operating pressure **MUST NOT** exceed the pressure rating of the lowest-rated component in the system. It is good practice to use a pressure gauge to monitor the entire system.
- Only use hydraulic tools/cylinders in a complete and tested, coupled system. **NEVER** attempt to use a tool/cylinder that is not correctly coupled to its operational pump. **NEVER** pressurise an uncoupled coupler/s.
- **NEVER** attempt to disconnect a hose from a hydraulic system until the systems pressure has been completely released. Doing so can result in that pressure becoming trapped within the system and relieving trapped pressure can be dangerous.
- **NEVER** try to relieve trapped hydraulic pressure in the system by loosening or attempting to remove the coupler. Trapped hydraulic pressure can cause a loosened coupler to dislodge unexpectedly with great force. This action could result in serious personal injury or death, as the coupler could become a projectile and hit operatives in the working area.
- Loosening a coupler under pressure can result in the escape of hydraulic oil at high pressure, which can penetrate the skin and cause significant injury or death.
- **NEVER** use a hammer and punch to unseat a coupler check valve that is under pressure. Doing so could result in the sudden, uncontrolled release of hydraulic oil at high pressure, which could cause significant injury or death.
- Immediately replace any worn or damaged parts using genuine Hi-Force parts only.
- **DO NOT** remove any labels from the product. Replace any damaged or unreadable label immediately.



## **CAUTION!**

Failure to observe and obey the following safety precautions could result in property damage, equipment damage or minor/moderate personal injury;

- **NEVER** lift or carry any hydraulic components by the hose or hoses connected to them.
- Avoid damaging hydraulic hose. **ALWAYS** route hoses to ensure that they are free from sharp bends and kinks. Using a bent or kinked hose will result in severe back-pressure, which can lead to hose failure.
- **ALWAYS** operate the system under no-load conditions before the actual operation, to ensure there is no air trapped in the hydraulic circuit.
- Servicing of hydraulic equipment must only be undertaken by a qualified technician.



- **DO NOT** drop or place heavy objects on a hydraulic hose, as this may cause internal damage, which could result in rupture of the pressurised hose. A ruptured hose could cause significant damage to components and possible severe injury to personal operating nearby.

## 2.4 Hydraulic Pump Specific Safety Precautions

 **WARNING!** Failure to observe and obey the following safety precautions could result in property damage, serious personal injury or death;

- **NEVER** invert the pump or lay it on its side, either in use, in transport or in storage.
- **DO NOT** weld any items to the pump or modify it in any way from its delivered condition. Your warranty may be invalidated, and it could lead to serious personal injury.
- **NEVER** exceed the maximum rated capacity of any hydraulic cylinder/tool. Hi-Force manufactures its hydraulic pumps to operate at a maximum working pressure of 700 BAR (10,000 PSI). **DO NOT** connect a cylinder/tool with a lower pressure capacity rating to any Hi-Force pump of this model series.
- This pump is not suitable for work which takes place in explosive environments.

 **CAUTION!** Failure to observe and obey the following safety precautions could result in property damage, equipment damage or minor/moderate personal injury;

- **ALWAYS** stand the pump on a stable level surface during operation.
- **BEWARE** of hot surfaces on the motor. Do not obstruct the flow of cooling air around the motor.
- To protect your warranty, only use the hydraulic oil grade as specified in Section 5.2.

## 3.0 Declaration of Incorporation / Conformity

Hi-Force declares that this product has been tested and complies with the standards set out in the relevant EU directives. The EU Declaration of Incorporation / Conformity is included as Annex A to this instruction document and is supplied with all shipments of this product.

## 4.0 Component Identification

1	Hydraulic Oil Drain Plug	8	Adjustable Pressure Relief Valve
2	Hydraulic Oil Level Gauge	9	Oil Reservoir
3	Hydraulic Service Connections *	10	Electrical Enclosure
4	Directional Control Valve **	11	Oil Filler Breather Cap
5	700 bar Pressure Gauge	12	Motor ***
6	Protective Roll Frame	13	On/Off Switches
7	Cable Winding/Stowage Hooks	-	

\* One or two ports, depending on valve type.

\*\* If fitted (Type will vary)

\*\*\* Motors will vary depending on supply requirements

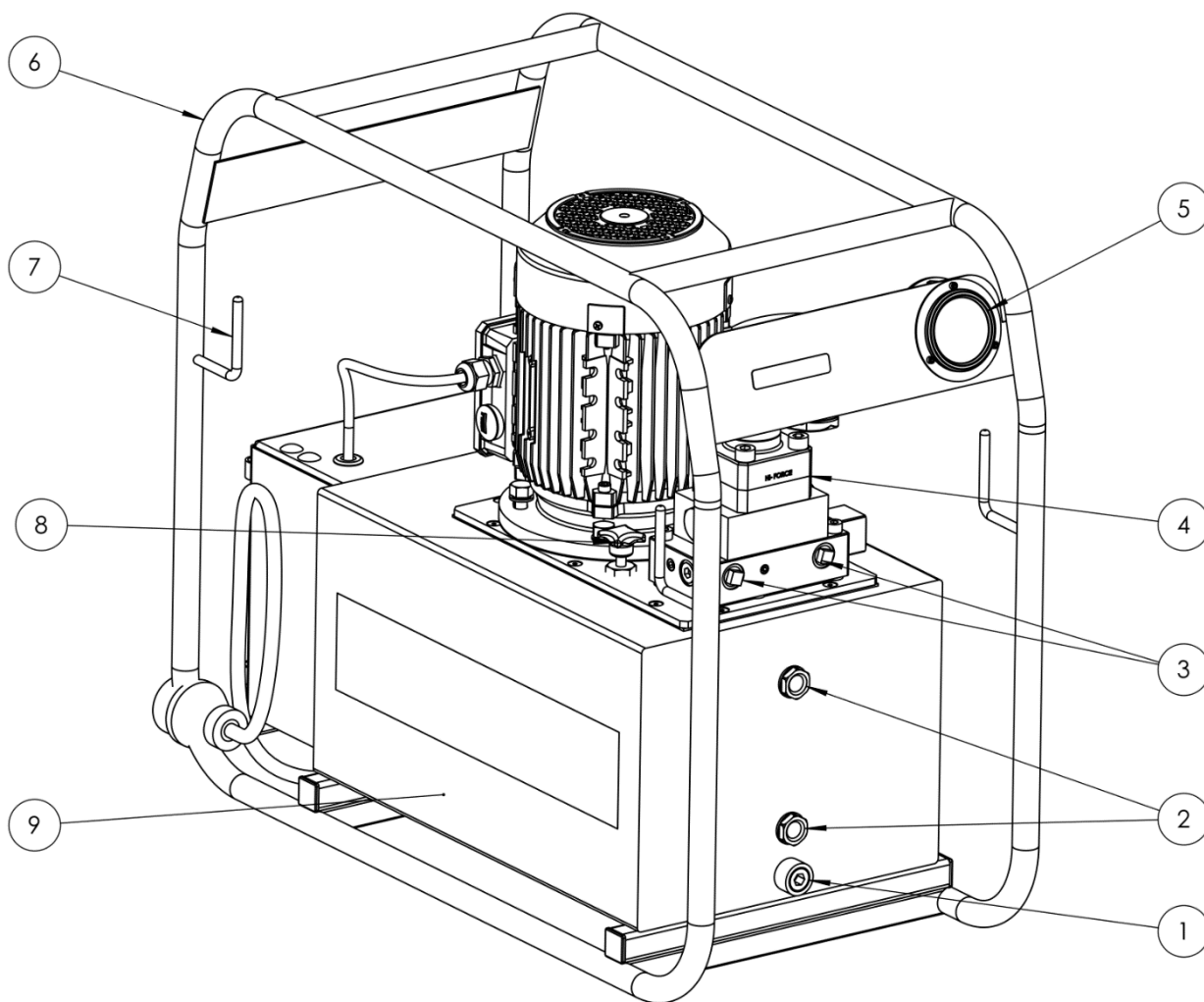

Figure 4.1: Component Identification

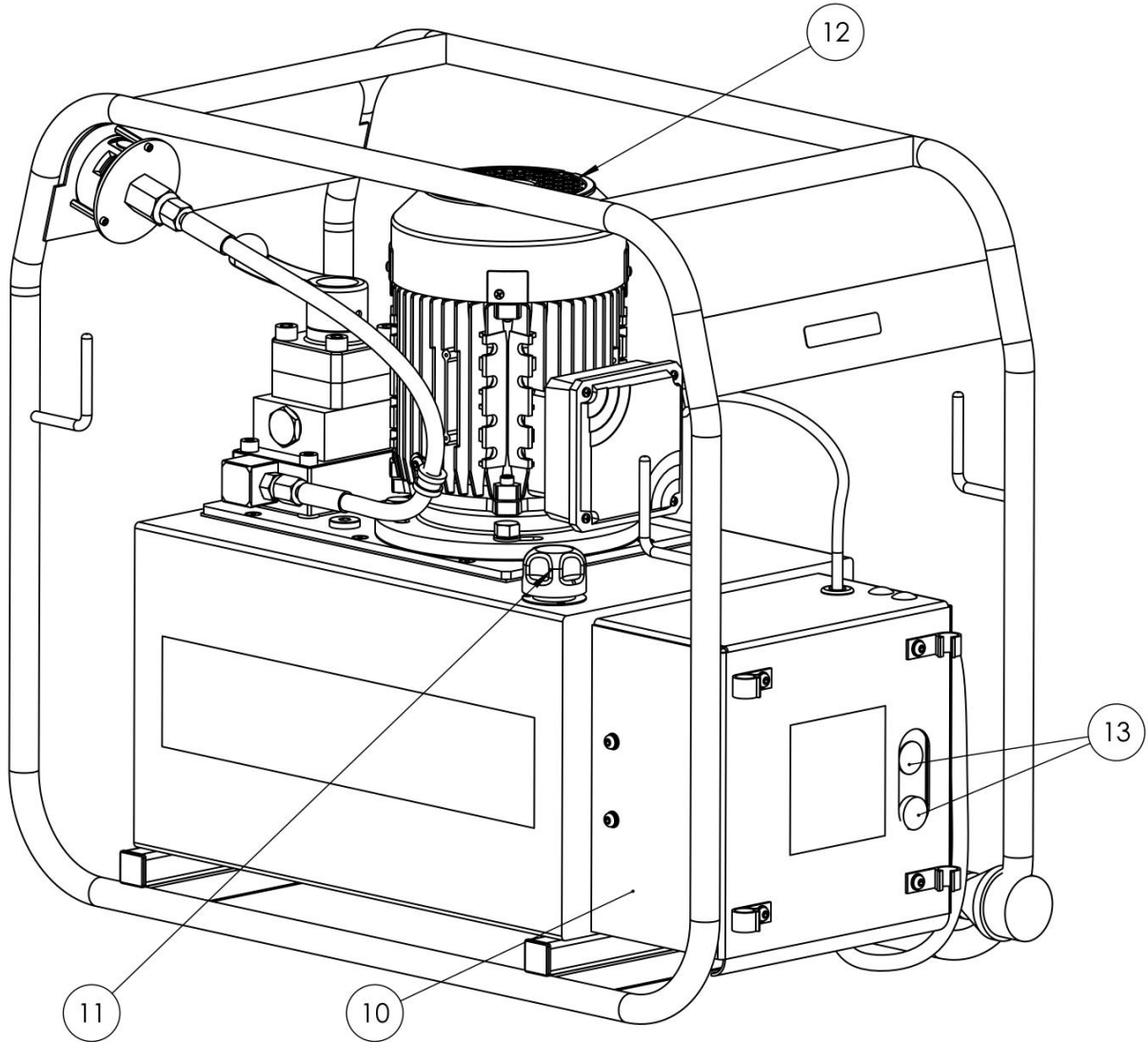

Figure 4.2: Component Identification



## 5.0 Installation/Setup

### 5.1 Before First Use

1. Immediately after unpacking, examine the pump for signs of transit damage and if found contact the shipping company.
2. Remove the temporary transit fitting / plate which is fitted in the position of the oil filler breather cap (11) and fit the oil filler breather cap which is packed separately.
3. Establish the oil level in the oil reservoir using the level gauges (2). Depending on the shipping method used, the reservoir may either be supplied full or empty. If the reservoir is empty it must be correctly filled before use (See section 5.2). If the pump was supplied full of oil, no further action is required.

**IMPORTANT:** Running the pump without oil will result in damage.

**CAUTION:** Ensure the oil level does not fall below the minimum level as shown by the lower indicator (2).

4. Remove the steel or plastic hexagon headed plugs and make hydraulic connections to the service ports (3). These ports have a 3/8" NPT female thread and the corresponding male connections should be wrapped with PTFE tape or other suitable sealant.

**NOTE:** On a pump equipped with a 3-way valve the service port is the one on the right-hand side, when viewed from the front. (See figure 4.1).

5. Ensure the lever of the hydraulic directional control valve (4) is set to the neutral position: This is fully anti-clockwise for models with a 2-way valve, or the central position for models with a 3-way or 4-way valve.

**NOTE:** Where valves are remotely mounted, make sure they are adjusted such that pressure will not build up during the starting operation. See section 8 for applicable models.

6. Make sure that the voltage indicated on the motor rating plate corresponds with the available supply.
7. Connect the motor to required power source. (See section 5.3)
8. Check the direction of rotation of the motor by pressing the green 'ON' button (13), then immediately pressing the red 'OFF' button. While doing this observe the motor fan. The motor should run in a clockwise direction when viewed from above. If the motor turns anti-clockwise, check the wiring of the electrical connector.

**CAUTION:** Running the pump with the motor turning in the incorrect direction may damage the low-pressure pump unit.



9. The pump is fitted with an adjustable pressure relief valve (8) to restrict the output pressure to any desired value, up to the maximum working pressure of the pump.

**Check the adjustable pressure relief valve is working:**

**NOTE:** Checking / setting the relief valve pressure is to be done with the hydraulic female couplers fitted to the service ports only.

- Press the green 'ON' button (13) and turn the directional control valve to the advance position (for 2 way valves turn the lever fully clockwise, for the 3 and 4-way valves turn the lever fully anti-clockwise and for the solenoid valves press and hold the 'advance' button on the pendant).
- Then release the locking feature and turn the control knob clockwise to increase the relief valve setting (the pressure reading on the gauge should increase) and anti-clockwise to decrease the relief valve setting (the pressure reading on the gauge should decrease).

### **5.2 Filling the Pump with Oil**

**IMPORTANT:** The HEP2 & HEP3 series of hydraulic pumps use **ISO46 Grade Hydraulic Oil**.

- Stand the pump on a firm, level surface.
- Remove the filler cap (11) from the filler breather.
- Fill the reservoir with clean, high quality ISO46 hydraulic oil via the filler breather until the oil level reaches the upper level indicator (2).
- Replace the filler cap (11) on the filler breather.

**NOTE:** More hydraulic oil can be added to the reservoir to assist with cooling if required, but **NEVER** more than 25mm below the tank lid.

**IMPORTANT:** Only add oil to the reservoir when the connected cylinder/tool is fully retracted. Failure to do so will result in the system containing more oil than the reservoir can hold.

### **5.3 Electrical Connection**

Before making an electrical connection, refer to the data plate located on the motor (12) for voltage and current requirements. Once satisfied the supply is suitable, an electrical connection can be made.

**NOTE:** Supply voltages vary from country to country. Hi-Force pumps will operate within the normal voltage tolerance ranges, but in extreme cases where they are operated for long periods at high pressures and in low voltage conditions, the motor may overheat and shut down.

**NOTE:** A common cause of pump failure is the use of long extension cables to connect the pump to the mains supply. The pump should be situated as close as possible to the wall outlet.

## 5.4 Hydraulic Connections

Connect the hydraulic hose/s between the cylinder/tool and the pump, ensuring that the coupling/s (if fitted) are **fully hand-tightened only**. **NEVER** use wrenches in an attempt to connect the coupling/s. Incorrectly connected coupling/s are one of the most common causes of faulty operation.

**IMPORTANT:** Make sure that all coupler threads are fully engaged.

## 5.5 Bleeding Trapped Air from the System



**WARNING!** The bleeding of trapped air from a hydraulic system must only be performed by qualified personnel who have been trained and are competent to do so.

Cylinders, tools and hoses are not always completely filled with oil when new. For safe and efficient operation, trapped air must be removed from the system. The follow procedure must be carried out with the cylinder/tool connected to the pump, but not operating under load.

To remove air from the system, proceed as detailed below:



Figure 5.1

- Make sure the oil filler breather cap (11) is fitted.
- With all hydraulic connections made, position the cylinder/tool below the level of the hydraulic pump, as illustrated in figure 5.1.

**Single-Acting:** With smaller single-acting cylinders, position them with the piston facing downward, as illustrated in figure 5.1

**Double-Acting:** If possible, position double-acting cylinders on their side with the couplers facing upward, as illustrated in figure 5.2



Figure 5.2

- Using the pump, fully advance and retract the cylinder/tool piston several times until the operation is smooth. (See section 6 for details of pump operation).

**NOTE:** When longer hoses are used (especially in the case of smaller capacity cylinders), the above procedure may not remove all the air from the system. In these cases, contact your Hi-Force representative for advice on pre-filling hoses with hydraulic oil.

## 6.0 Operation

Hi-Force will not always be aware of what equipment this pump will be used to power. It is the responsibility of the owner and all operators to read, understand and comply with all appropriate safety warnings and operating instructions relating to the equipment being used.

### 6.1 Setting the Pressure Relief Valve

**NOTE:** Setting the relief valve pressure is to be done with hydraulic female couplers fitted to the service ports only. I.e. No hoses or cylinders/tools fitted.

The procedure for setting the relief valve pressure is as follows:

- Turn the pump on by pressing the green 'ON' button (13)
- Place the pump in advance mode.

For 2-Way manual valves, turn the level fully clockwise (See figure 6.1).

For 3 & 4-Way manual valves, turn the lever fully anti-clockwise (See figure 6.2).

For solenoid valves, press and hold the 'advance' button on the pendant.

#### **Increasing the Pressure Setting**

- Release the locking feature and turn the control knob slowly (8) clockwise until the required pressure is read on the pressure gauge.
- Engage the locking feature to lock the relief valve at the desired pressure.

#### **Decreasing the Pressure Setting**

- Release the locking feature and turn the control knob (8) anti-clockwise until a pressure value lower than the required pressure is read on the gauge.
- Turn the control knob slowly clockwise until the required pressure is read on the gauge.
- Engage the locking feature to lock the relief valve at the required pressure.

**NOTE: ALWAYS** adjust up to the desired pressure and **NEVER** down. When setting the pump to a lower pressure, reduce the pressure below the desired value (anti-clockwise) and then increase back up to the desired pressure (clockwise) as read on the gauge.

**NOTE:** It's good practice to zero the pressure before storing away. Turn the control knob anti-clockwise until the pressure gauge reads zero.

## 6.2 Pumps with Manual Valves

1. Set the adjustable pressure relief valve (8) if required. See section 6.1 for details.
2. With all hydraulic connections and an electrical connection made turn the motor on by pressing the green 'ON' button (13).
3. Operate the directional control valve (4) to control the cylinder/s or tool/s in use.

For pumps with a 2-way valve: Turning the lever fully clockwise will supply oil to the service port and advance the cylinder/tool. Turning the lever anti-clockwise will retract the cylinder/tool. (See figure 6.1)

For pumps with a 3-way or 4-way valve: Mid position is the load hold position. Turning the lever so that it is above the service port (anti-clockwise) will supply oil to the service port and advance the cylinder/tool. Moving the lever away from the service port (clockwise) will connect the service port to the tank and retract the cylinder/tool. (See figure 6.2)

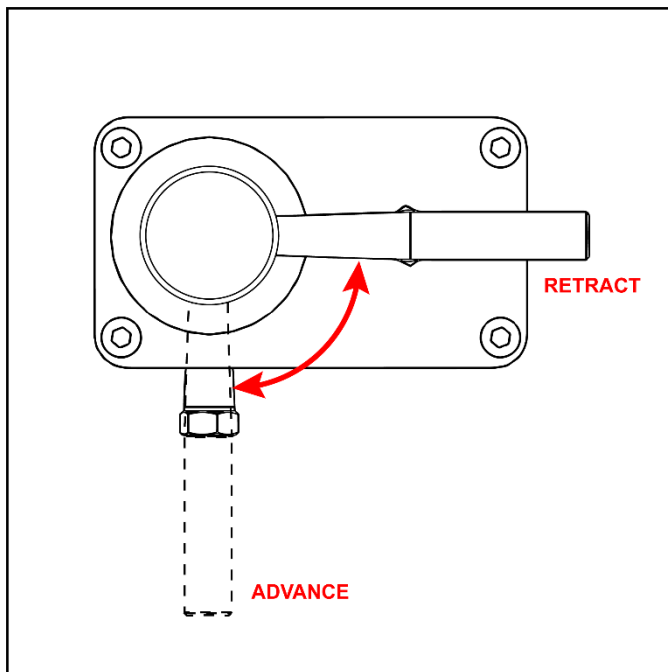

Figure 6.1: 2-Way Manual Valve

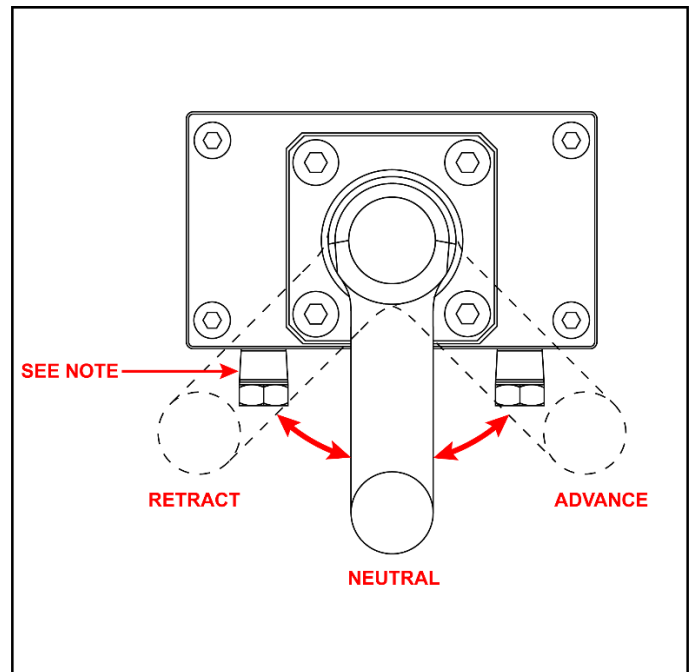

Figure 6.2: 3 & 4-Way Manual Valves  
NOTE: 2<sup>nd</sup> Port only on 4-Way Valves

### **6.3 Pumps with Solenoid Valves**

1. Set the adjustable pressure relief valve (8) if required. See section 6.1 for details.
2. With all hydraulic connections and electrical connection made and turn the motor on by pressing the green 'ON' button (13).
3. Press and hold the 'advance' button on the pendant to advance the cylinder/tool. Release the button once the cylinder/tool has been advanced the desired amount. The cylinder/tool will remain in the load holding position when the button is released.
4. Press and hold the 'retract' button to retract the cylinder/tool. Release the button once the cylinder/tool has been retracted.

**IMPORTANT:** ALWAYS fully retract the cylinder/tool at the end a job/operation, before any disconnections are made.

### **7.0 Maintenance and Storage**

- Inspect the pump for damage after each use.
- Change the oil every 500 working hours using high quality ISO46 hydraulic oil.
- Zero the pump pressure before storing.
- Have the pump serviced regularly by a Hi-Force authorised repair centre.

## 8.0 Specifications

An average A-Weighted sound pressure level of 75dB was measured for undefined workspaces, as per EU Directive 2006/42/EC Section 1.7.4.2 (u).

### 8.1 HEP2 Specifications

Refer to the nameplate on the pump for model identification.

Refer to section 8.3 for motor electrical characteristics.

HEP2   ELECTRIC DRIVEN PUMPS – GENERAL DUTY, MEDIUM FLOW						
Model Number	Valve Type	Oil Capacity	Maximum Flow Rate (litres/minute)		Motor Voltage	Weight
		(litres)	1 <sup>st</sup> Stage	2 <sup>nd</sup> Stage		(kg)
HEP207111	P-T Plate	10	7	0.65	110V 50 Hz-1Ph	52.0
HEP207112	P-T Plate	10	7	0.65	230V 50 Hz-1Ph	52.0
HEP207114	P-T Plate	10	7	0.65	400V 50 Hz / 460V 60 Hz-3Ph	52.0
HEP207121	P-T Plate	25	7	0.65	110V 50 Hz-1Ph	68.0
HEP207122	P-T Plate	25	7	0.65	230V 50 Hz-1Ph	68.0
HEP207124	P-T Plate	25	7	0.65	400V 50 Hz / 460V 60 Hz-3Ph	68.0
HEP207211	2-way	10	7	0.65	110V 50 Hz-1Ph	52.5
HEP207212	2-way	10	7	0.65	230V 50 Hz-1Ph	52.5
HEP207214	2-way	10	7	0.65	400V 50 Hz / 460V 60 Hz-3Ph	52.5
HEP207221	2-way	25	7	0.65	110V 50 Hz-1Ph	68.5
HEP207222	2-way	25	7	0.65	230V 50 Hz-1Ph	68.5
HEP207224	2-way	25	7	0.65	400V 50 Hz / 460V 60 Hz-3Ph	68.5
HEP207311	3-way	10	7	0.65	110V 50 Hz-1Ph	52.5
HEP207312	3-way	10	7	0.65	230V 50 Hz-1Ph	52.5
HEP207314	3-way	10	7	0.65	400V 50 Hz / 460V 60Hz-3Ph	52.5
HEP207321	3-way	25	7	0.65	110V 50 Hz-1Ph	68.5
HEP207322	3-way	25	7	0.65	230V 50 Hz-1Ph	68.5
HEP207324	3-way	25	7	0.65	400V 50 Hz / 460V 60 Hz-3Ph	68.5
HEP207411	4-way	10	7	0.65	110V 50 Hz-1Ph	52.5
HEP207412	4-way	10	7	0.65	230V 50Hz-1Ph	52.5
HEP207414	4-way	10	7	0.65	400V 50 Hz / 460V 60 Hz-3Ph	52.5
HEP207421	4-way	25	7	0.65	110V 50 Hz-1Ph	68.5
HEP207422	4-way	25	7	0.65	230V 50 Hz-1Ph	68.5
HEP207424	4-way	25	7	0.65	400V 50Hz / 460V 60 Hz-3Ph	68.5

## 8.2 HEP3 Specifications

Refer to the nameplate on the pump for model identification.

Refer to section 8.3 for motor electrical characteristics.

HEP3   ELECTRIC DRIVEN PUMPS – GENERAL DUTY, HIGH FLOW						
Model Number	Valve Type	Oil Capacity	Maximum Flow Rate (litres/minute)		Motor Voltage	Weight
		(litres)	1 <sup>st</sup> Stage	2 <sup>nd</sup> Stage		(kg)
HEP310121	P-T Plate	25	9	1	110V 50Hz-1Ph	68.0
HEP310122	P-T Plate	25	9	1	230V 50Hz-1Ph	68.0
HEP310124	P-T Plate	25	9	1	400V 50 Hz / 460V 60 Hz-3Ph	68.0
HEP310221	2-way	25	9	1	110V 50 Hz-1Ph	68.5
HEP310222	2-way	25	9	1	230V 50 Hz-1Ph	68.5
HEP310224	2-way	25	9	1	400V 50 Hz / 460V 60 Hz-3Ph	68.5
HEP310321	3-way	25	9	1	110V 50Hz-1Ph	68.5
HEP310322	3-way	25	9	1	230V 50Hz-1Ph	68.5
HEP310324	3-way	25	9	1	400V 50 Hz / 460V 60 Hz-3Ph	68.5
HEP310421	4-way	25	9	1	110V 50Hz-1Ph	68.5
HEP310422	4-way	25	9	1	230V 50Hz-1Ph	68.5
HEP310424	4-way	25	9	1	400V 50 Hz / 460V 60 Hz-3Ph	68.5

## 8.3 HEP2 / HEP3 Pump Electrical Characteristics

Refer to the nameplate on the pump for model identification.

Motor Voltage	Motor Frequency	Motor Current	Motor Output
110V-1Ph	50 Hz	16 A	1.1 kW
230V-1Ph	50 Hz	9.3 - 9.6 A	1.5 kW
400V-3Ph	50 Hz	3.6 A	1.5 kW
460V-3Ph	60 Hz	3.2 A	1.5 kW



## **9.0 System Components / Accessories**

*(Refer to the Hi-force website or latest Hi-Force catalogue, Section: System Components for further details)*

- High Pressure Hydraulic Hoses
- Manifolds and Manifold Assemblies.
- Flow Control Valve
- Pressure Gauges and Gauge Mounting Blocks
- High-Pressure Couplings and Fittings

## 10.0 Troubleshooting

Hi-Force HEP2 & HEP3 electric driven hydraulic pumps should be serviced and repaired only by authorised Hi-Force repair centres. The following table gives possible causes and solutions for common problems.

<b>TROUBLESHOOTING GUIDE</b>		
<b>Problem</b>	<b>Possible Cause</b>	<b>Solution</b>
1. Pump will not start.	a. Power not connected.	Connect power.
	b. Damaged power cord.	Repair or replace power cord.
	c. Circuit breaker tripped.	i. Reset Circuit breaker. ii. Ensure breaker is adequately rated.
	d. Damaged pendant.	Contact your local Hi-Force office/distributor.
	e. Blown fuse.	Replace blown fuse.
	f. Burnt out motor.	Contact your local Hi-Force office/distributor.
2. Motor stalls before full operating pressure is reached.	a. Low supply voltage.	i. Use heavier gauge extension cord. ii. Turn off excess electrical loads.
3. Pump runs but will not build up to full operating pressure.	a. Reservoir breather has not been installed.	Remove transit plate and install reservoir breather as per section 5.1
	b. Low oil level.	Add oil as per section 5.2.
	c. Adjustable relief valve incorrectly set.	Adjust relief valve pressure as per section 6.1.
	d. External oil leak in system.	Contact your local Hi-Force office/distributor.
4. Noisy Operation	a. Air trapped in the system.	Bleed air from the system as per section 5.5
	b. Low oil level	Add oil as per section 5.2
	c. Reservoir breather has not been installed.	Remove transit plate and install reservoir breather as per section 5.1
5. Pump builds to full pressure, but cylinder/tool does not advance/operate.	a. Advance or return flow line to cylinder/tool restricted or blocked.	Check couplers (if fitted) for full engagement.
6. Pump running hot.	a. Low oil level.	Add oil as per section 5.2.
	b. Advance or retract flow restricted.	Check couplers (if fitted) for full engagement.
	c. High pressure leakage at pump.	Contact your local Hi-Force office/distributor.

**TROUBLESHOOTING GUIDE (continued...)**

Problem	Possible Cause	Solution
7. Cylinder/tool not functioning correctly.	a. Cylinder/tool incorrectly connected to pump.	Check for correct system setup. Check couplers (if fitted) for full engagement
	b. Pump solenoid faulty.	Contact your local Hi-Force office/distributor.
	c. Cylinder/tool fault.	See cylinder/tool's troubleshooting guide or contact your local Hi-Force office/distributor.
	d. Low oil level	Add oil as per section 5.2.
	e. Air trapped in the system	Bleed air from the system as per section 5.5
8. Cylinder/tool will not retract.	a. Valve malfunction.	Contact your local Hi-Force office/distributor.
	b. Return flow line restricted or blocked.	i. Check couplers (if fitted) for full engagement. ii. Run motor while retracting cylinder/tool.
9. Pressure gauge does not read zero when pump motor is stopped.	a. Pressure not relieved from system.	Turn the adjustable pressure relief valve (8) fully anti-clockwise to release the pressure.
10. Gauge displays no pressure reading.	a. Faulty gauge.	Contact your local Hi-Force office/distributor
	b. Pump will not build pressure.	See problem 3 above.

**Head Office:**

Hi-Force Limited

Prospect Way, Daventry

Northamptonshire NN11 8PL

United Kingdom

Tel: + 44 1327 301000 | Fax: + 44 1327 706555

[www.hi-force.com](http://www.hi-force.com)

**Regional Offices:**

For information on our offices worldwide, scan the below QR code

