

This 'Original instructions' document assumes that the operator carrying out any operation with this product is trained and competent to do so. This manual does not attempt to cover all details or variations in the equipment. Nor does this manual claim to provide for every possible contingency met in connection with the installation, operation, or maintenance thereof. Should further information be desired, or should a particular problem arise which is not covered in sufficient detail, the matter should be referred to Hi-Force.

OPERATING INSTRUCTION MANUAL

TLA50 SERIES | TOUGHLIFT JACKING SYSTEM - AIR DRIVEN

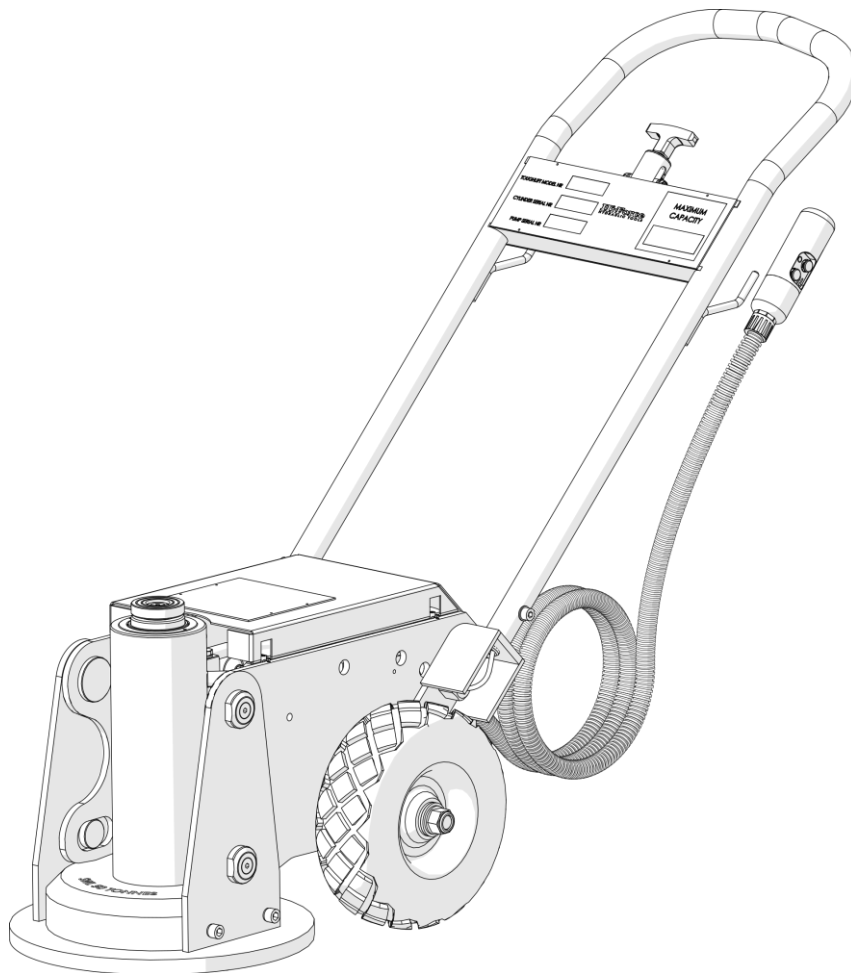

Hi-Force TLA50 series Air Driven ToughLift Jacking Systems are designed to be an easy to operate, all-in-one air-powered jacking system. The mobile unit is easy to manoeuvre and the combination of an adjustable handle and the 'V-Lift' system facilitates easy, accurate positioning of the lifting cylinder under the load. Available with a 254mm or 355mm stroke length, the units have a lifting capacity of 50 tonnes at a maximum operating pressure of 700 bar (10,000 psi). This manual applies to the Hi-Force TLA50 series Air Driven ToughLift Jacking Systems Only. It contains the latest product information available at the time of publication and approval. For information relating to the servicing of an Air Driven ToughLift, see the servicing instructions, which are available on the Hi-Force website. Hi-Force reserves the right to make changes to this document at any time without notice.

Table of Contents

1.0 Inspection upon Receipt3

2.0 Safety Precautions.....3

3.0 Declaration of Incorporation/Conformity6

4.0 Component Identification.....7

5.0 Installation/Setup11

6.0 Operation14

7.0 Lifting and Transport.....15

8.0 Maintenance and Storage.....16

9.0 Specifications.....17

10.0 System Components/Accessories17

11.0 Troubleshooting.....18

12.0 Contact Details20

NOTE: Images contained within this document are for illustrative purposes **ONLY**.

1.0 Inspection upon Receipt

Upon receipt of the product, visually inspect the item for any evidence of shipping damage. Please note: the warranty does not cover shipping damage. Notify the courier immediately if shipping damage is found and refrain from putting the product into service. The carrier is responsible for repair and replacement costs resulting from damage that occurred in transit.

2.0 Safety Precautions

2.1 Introduction



Read and follow all the instructions and safety warnings carefully before handling, installation or use of any hydraulic equipment. Failure to do so could lead to equipment damage, equipment failure, personal injury or even death. Hi-Force will not be held responsible for any damage to the equipment, injury or death resulting from the unsafe use of, lack of maintenance to, or incorrect operation of the product. If in doubt on the correct use of any Hi-Force equipment, contact your nearest Hi-Force office or distributor. Only qualified personnel should be allowed to operate hydraulic equipment. If an operator has not been trained on high-pressure hydraulic equipment and its safe usage, consult your local Hi-Force sales office or distributor who can offer training courses for operators.

2.2 Work Area Safety

- Keep work areas clean and well lit. Cluttered spaces and inadequate lighting can result in unnecessary accidents.
- Keep bystanders clear of any hydraulic tool activity. Personnel working in close-range should be made aware of all high-pressure work before commencing.
- Ensure that the lifting device/s are placed entirely under the load and that lifting is parallel.

2.3 General Hydraulic System Safety Precautions



WARNING! Failure to observe and obey the following safety precautions could result in property damage, significant personal injury or death;



- When operating any hydraulic equipment, all operators should ensure that all necessary personal protective equipment (PPE) is worn, as specified by their employer. Steel toe-cap safety shoes, safety glasses/visor, and protective gloves should be worn at all times. All relevant risk assessments should be completed before the use of the equipment.
- Keep hydraulic equipment away from open flames and direct heat.
- **NEVER** use a coupler as a tool handle, especially if the system is pressurised.

- **NEVER** handle a pressurised hydraulic hose. Hydraulic fluid escaping under pressure from a ruptured hose can penetrate the skin and lead to a significant medical emergency, and in some cases, death. Should this incident occur, seek out medical attention immediately.
- Seek medical attention immediately if a hydraulic injection injury (no matter how minor) occurs.
- The system operating pressure **MUST NOT** exceed the pressure rating of the lowest-rated component in the system.
- Only use hydraulic tools/cylinders in a complete and tested, coupled system. **NEVER** attempt to use a tool/cylinder that is not correctly coupled to its operational pump. **NEVER** pressurise uncoupled couplers.
- **NEVER** attempt to disconnect a hose from a hydraulic system until the system's pressure has been completely released. Doing so can result in that pressure becoming trapped within the system and relieving trapped pressure can be dangerous.
- Loosening a hydraulic fitting under pressure can result in the escape of hydraulic fluid at high pressure, which can penetrate the skin and cause significant injury or death.
- **NEVER** attempt to solve, or clean-up leaks in the system while the system is pressurised.
- Immediately replace any worn or damaged parts using genuine Hi-Force parts only.
- **DO NOT** use any hydraulic equipment if you are under the influence of alcohol, drugs or medication. Lack of attention whilst operating high-pressure hydraulic tools can result in personal injury or death.



CAUTION!

Failure to observe and obey the following safety precautions could result in property damage, equipment damage or minor/moderate personal injury;

- **NEVER** lift, carry or move any hydraulic components by the hose or hoses connected to them.
- Avoid damaging hydraulic hoses. **ALWAYS** route hoses to ensure that they are free from sharp bends and kinks. Using a sharply bent or kinked hose will result in severe back-pressure, which can lead to hose failure.
- **NEVER** use a coupler/s to lift, carry or position a tool.
- Servicing of hydraulic equipment must only be undertaken by a qualified technician.

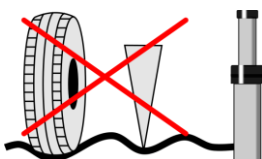

- **DO NOT** drop or place heavy objects on a hydraulic hose, as this may cause internal damage, which could result in rupture of the pressurised hose. A ruptured hose could cause significant damage to components and possible severe injury to personal operating nearby.

- **DO NOT** let familiarity gained with any hydraulic tools allow you to become complacent. Complacency with any tooling can result in a lack of discipline toward working guidelines and safety principles.

- **DO NOT** remove any labels from the product. Replace any damaged or unreadable labels immediately.
- Avoid loose clothing and jewellery that could get caught in moving parts, tie back long hair.

2.4 ToughLift Specific Safety Precautions

⚠ WARNING! Failure to observe and obey the following safety precautions could result in property damage, serious personal injury or death;

- **DO NOT** work under or near a load supported only by hydraulic means. A hydraulic cylinder/jack, when used as a lifting device, should not be used as a load-holding device. Once lifted, all loads should be supported using rigid mechanical structures.



- **NEVER** exceed the maximum rated pressure or load capacity of any hydraulic cylinder. Hi-Force manufactures its hydraulic cylinders to operate at a maximum working pressure of 700 bar (10,000 psi).
- **DO NOT** adjust or remove the external pressure relief valve on any Hi-Force product.
- **ALWAYS** place the unit on a flat, even surface that can support the load to be applied.

Where applicable, use an additional cylinder support base to assist in supporting the load to be lifted.

- Avoid lifting loads that are not central to the lifting piston. Avoid offset loading as this can damage the cylinder bores and piston rods, and also lead to unstable load lifting.
- **NEVER** invert the unit or lay it on its side, either in use, in transport or in storage.
- **DO NOT** weld any items to the ToughLift unit or modify it in any way from its delivered condition. Your warranty may be invalidated, and it could lead to serious personal injury.
- **ALWAYS** use friction material under the base plate of the unit and between the jack and the load.
- **ONLY** lift dead-weight (static) loads. **DO NOT** lift dynamic loads. i.e. Loads with a shifting centre of mass.
- **NEVER** exceed the maximum rated capacity of any hydraulic equipment. See section 9.
- Only use hydraulic cylinders in a complete and tested, coupled system. **NEVER** attempt to use a cylinder that is not correctly coupled to its operational pump.
- Overloading hydraulic cylinders can result in component failure and possible serious personal injury.
- Keep hands and feet away from the cylinder during operation.



CAUTION!

Failure to observe and obey the following safety precautions could result in property damage, equipment damage or minor/moderate personal injury;

- To protect your warranty, only use the hydraulic oil grade specified in Section 5.3.
- When moving the unit, make sure all air supply and control pendant hoses are kept clear of the wheels, to avoid possible damage, restriction or entanglement of the hose lines.

3.0 Declaration of Incorporation/Conformity

Hi-Force declares that this product has been tested and complies with the standards set out in the relevant EU directives. The EU Declaration of Incorporation/Conformity is included as Annex A to this instruction document and is supplied with all shipments of this product.

4.0 Component Identification

1	Base Plate	5	Tilting Saddle
2	'V' Lift System	6	Handle Release
3	Cylinder	7	Handle
4	Piston	8	Control Pendant

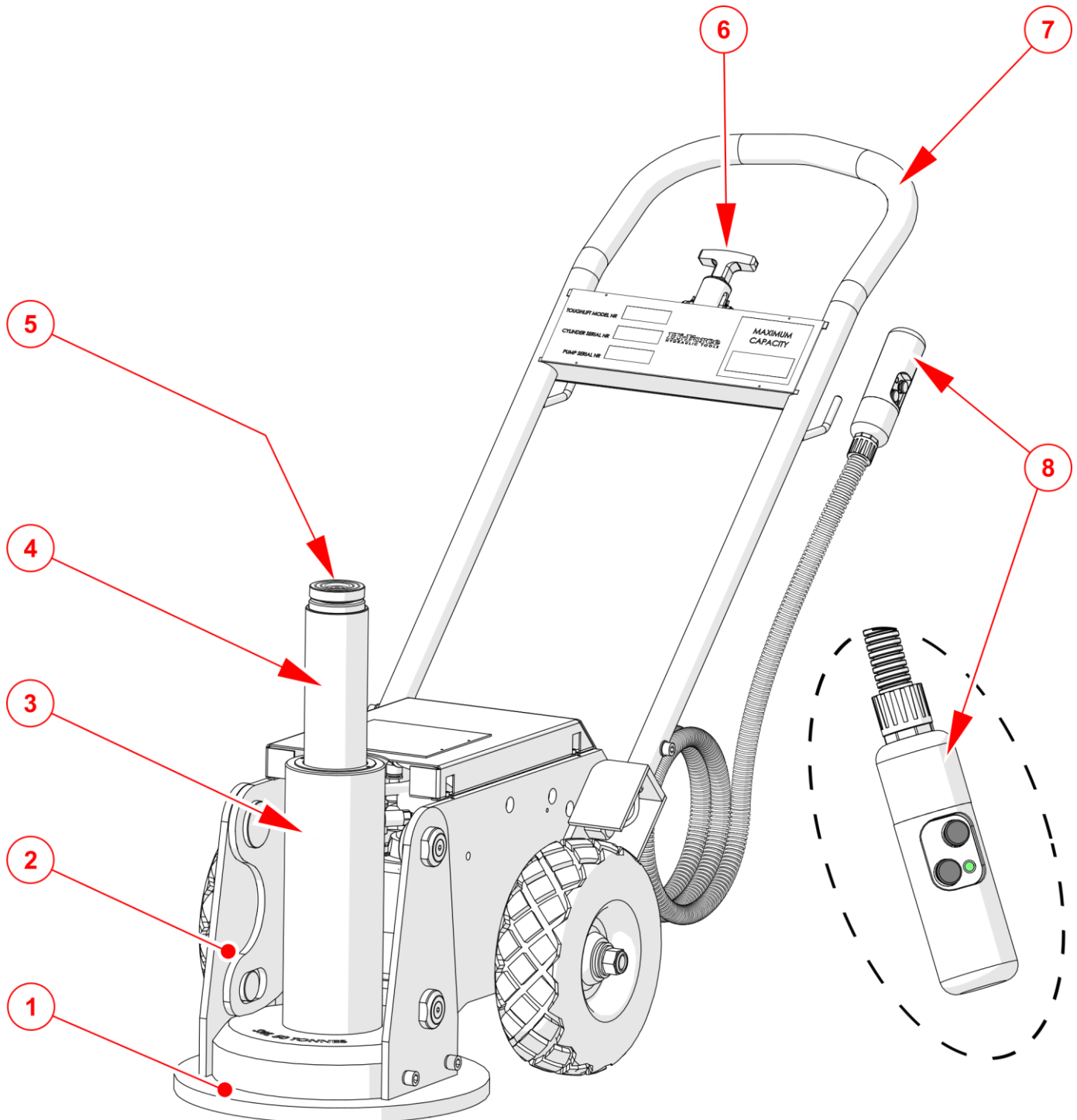

Figure 4.1: Component Identification

9	Oil Filler Breather Cap	11	Cylinder Overload Protection Valve
10	Air Motor	12	Air Motor Muffler

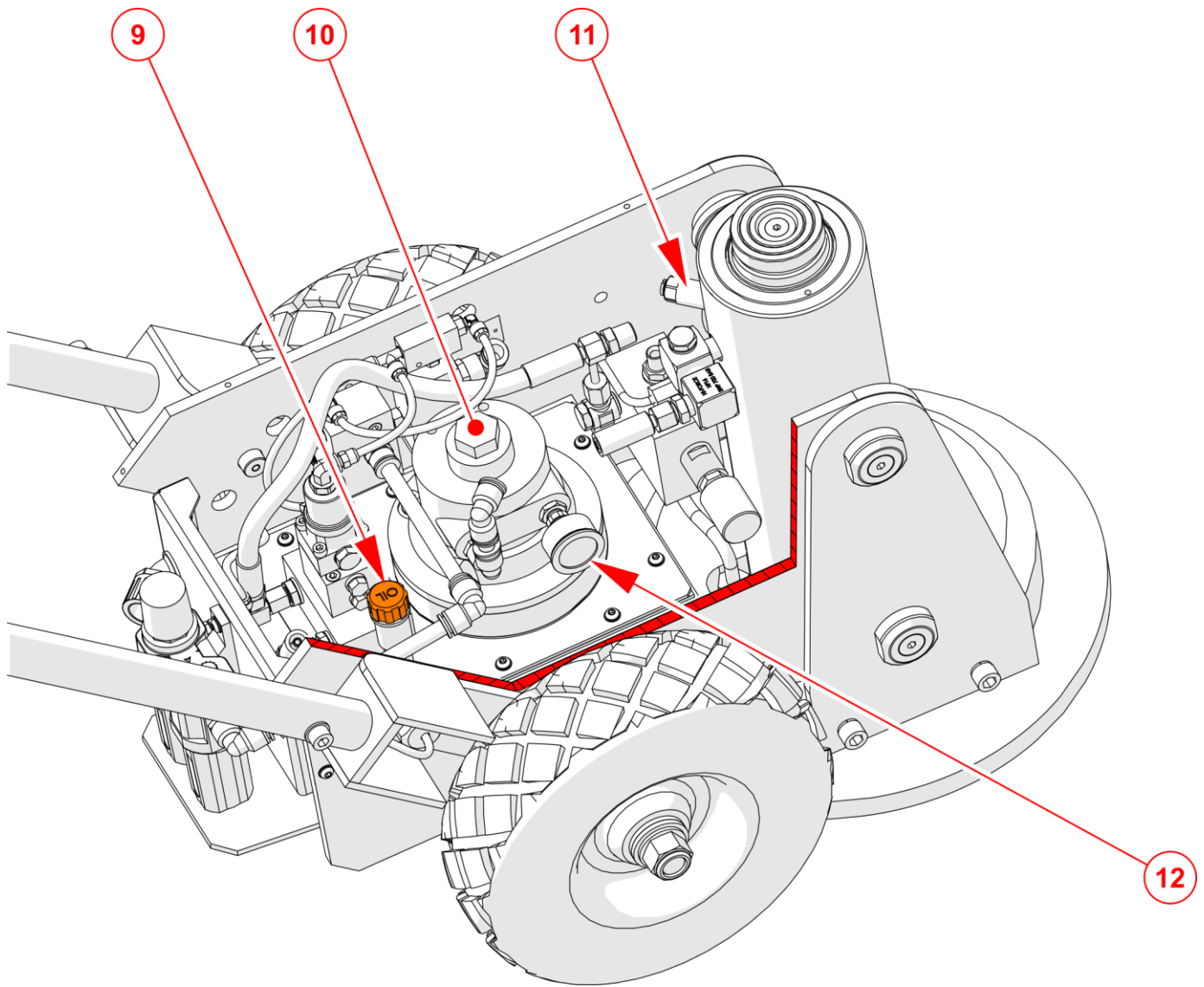

Figure 4.2: Component Identification

13	Top Cover	17	Oil Reservoir
14	Filter/Regulator/Lubricator (FRL) Unit	18	Handle Position Latch-Pin Holes
15	Pendant Hose Inlet	19	Top Cover Mounting Cap Screws
16	Oil Level Gauge	-	

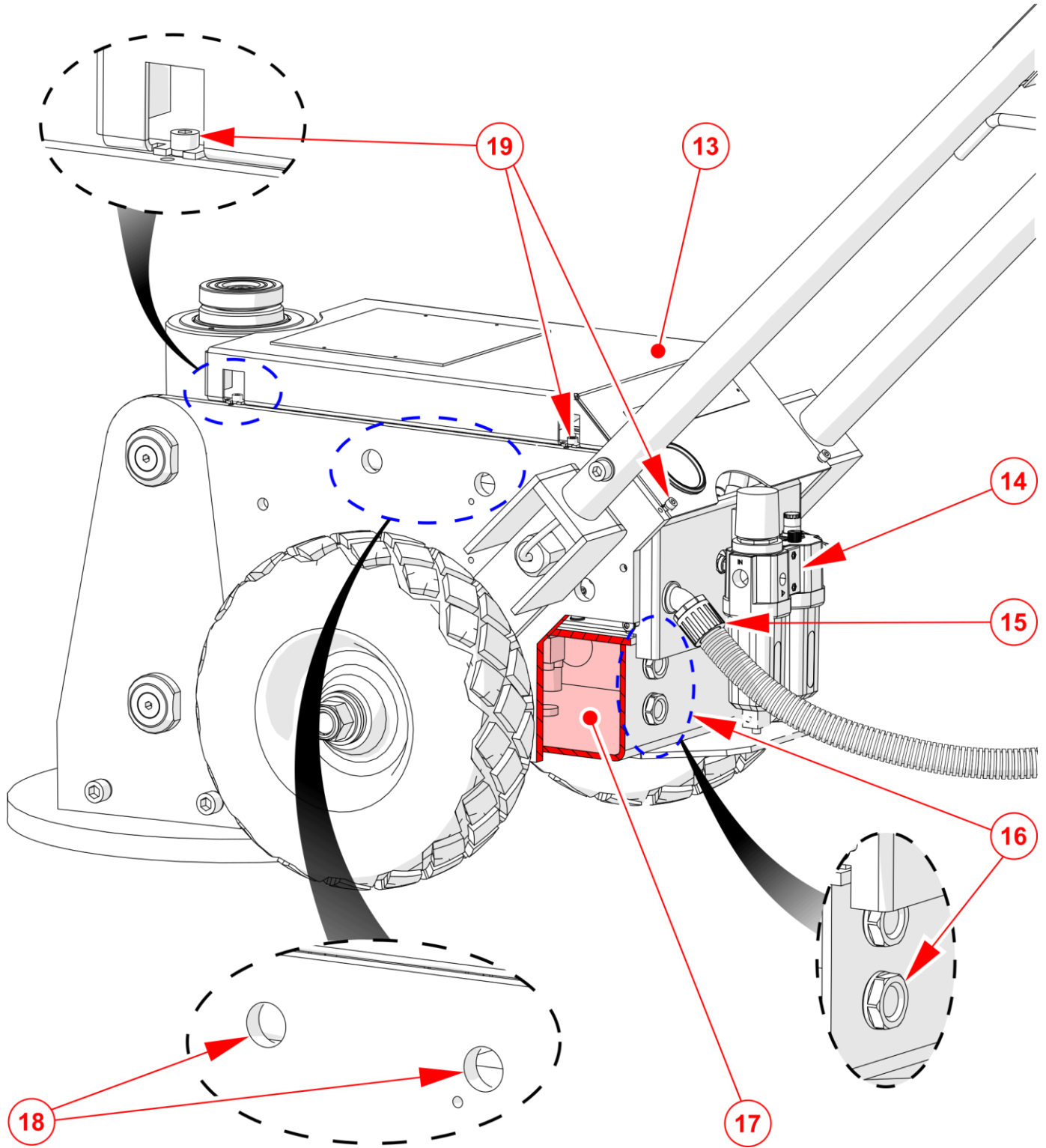

Figure 4.3: Component Identification

20	Water Trap Drain Button	25	Air Lubricator Filler Plug
21	Water Trap	26	Air Lubricator Control Knob
22	Air Supply Inlet Port	27	Air Lubricator Reservoir
23	Air Pressure Gauge	28	Water Trap Drain Port
24	Air Pressure Regulator Valve	29	Oil Reservoir Drain Plug

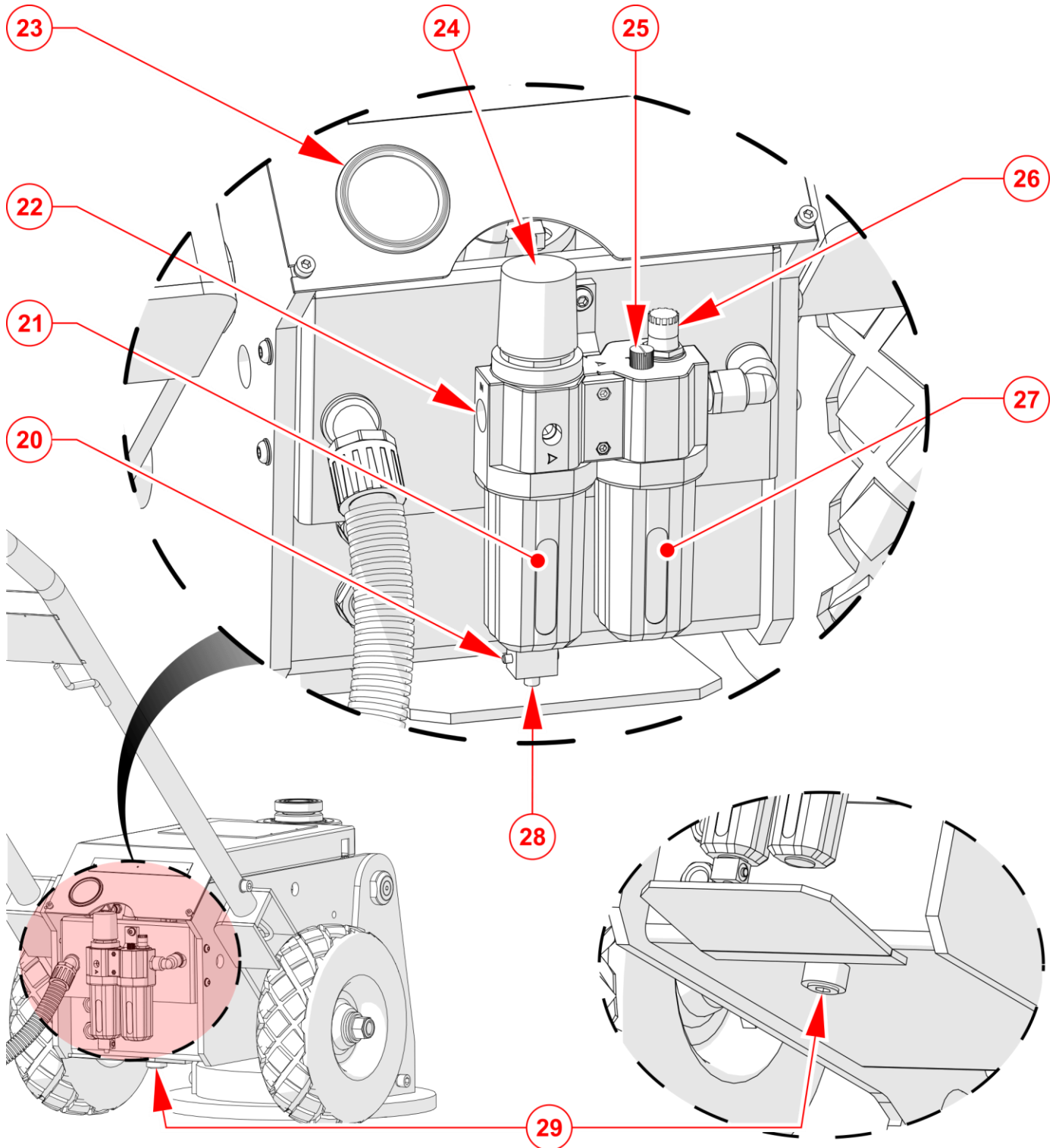

Figure 4.4: Component Identification

5.0 Installation/Setup

5.1 Before First Use / Preparation

1. Immediately after unpacking, examine the unit for signs of transit damage and if found contact the shipping company.
2. Establish the oil level in the oil reservoir (17) using the oil level gauge (16). Depending on the shipping method used, the reservoir may either be supplied full or empty. If the reservoir is empty, it must be correctly filled before use (See section 5.3). If the reservoir was supplied full of oil, no further action is required.

IMPORTANT: Running the pump without oil will result in damage.

5.2 Removing/Replacing the Top Cover (13) !!!IMPORTANT!!

⚠ CAUTION! Take care when removing the top cover. The units' air pressure gauge is mounted to the top cover and attaches via an airline hose to the main housing. When removing the top cover, move slowly, taking extra care to ensure the connecting hose does not snag or get pulled from its fittings.

⚠ CAUTION! When replacing the cover, gently feed the air pressure gauge hose into the main housing, making sure the hose does not get pinched between the top cover and the main housing.

5.3 Filling the Reservoir with Oil

IMPORTANT: The TLA50 Range uses **ISO46 Grade Hydraulic Oil**.

- Stand the ToughLift on a firm, level surface.
- Open the Top Cover (13), by removing the 6 Cap Screws (19) holding the cover in place. (See figure 4.3 - Item 19, for screw locations).
- Remove the filler cap (9) from the filler breather.
- Fill the reservoir with clean, high-quality ISO46 hydraulic oil via the filler breather until the oil level reaches the centre of the upper oil level gauge sight-glass (16).
- Replace the filler cap (9) on the filler breather.
- Replace the Top Cover (13) and 6 Cap Screws (19). **DO NOT** operate the ToughLift without the Top Cover securely in place.

⚠ CAUTION! Ensure the oil level does not fall below the minimum level. Running the pump without oil will result in damage.

IMPORTANT: Only add oil to the reservoir when the lifting cylinder is fully retracted. Failure to do so will result in the system containing more oil than the reservoir can hold.

5.4 Filling the Air Supply Lubricant Reservoir

IMPORTANT: The TLA50 Air Motor requires **ISO VG 32 (SAE10) Detergent Oil**.

- Turn Off or Disconnect from the Air Supply.
- Remove the Air Lubricator Filler Plug (25).
- Fill the Air Lubricant Reservoir (27) with **ISO VG 32** turbine oil to the fill line marked on the reservoir.
- Replace the Air Lubricator Filler Plug (25).

5.5 Air Supply Requirements

- The air supply must be delivered via a suitably rated air hose of at least 1/2" (13mm) diameter.
- The air supply pressure must be at least 5.5 bar (80 psi), but preferably 7 bar (100 psi).
- The compressor must be able to maintain a minimum flow rate of 50 cfm (24 l/sec).

NOTE: The pump will still run if the values are below those stated above, but the oil flow rate, and therefore the advance and retraction speed of the cylinder, will be reduced.

5.6 Airline Connection

The air supply must be connected (via a suitable fitting) to the 3/8" BSP inlet port (22) on the FRL Unit.

5.7 Air Lubricant Setting

Adjust the air lubricant control knob (26) such that 1 drop of lubricant is added to the air supply approximately every minute. The lubricant drops can be seen through the lubricant control knob (26) on the top of the unit. Allowing more oil than this into the motor can lead to contamination of the exhaust flow.

5.8 Priming the Pump / Bleeding Trapped Air from the System

If the unit is delivered without oil, or if air becomes trapped in the system, it will need to be primed/bled.

To do this, fully advance and retract the cylinder (unloaded) several times until operation is smooth.

5.9 Moving & Positioning the ToughLift

1. Adjust the handle into the most comfortable position by [1] pulling up on the handle release (6) and [2] rotating the handle (7) to the desired position. [3] Let go of the handle release (6) and allow the locating pins to engage the handle latch-pin holes (18) on the side of the ToughLift main housing (See figure 5.1).
2. Use the handle (7) to tilt the jack right back onto its wheels, allowing it to be manoeuvred to its required location (See figure 5.2).
3. Position the jack accurately under the lifting point by adjusting the handle to its lowest position and tilting the jack back slightly onto its wheels (See figure 5.3).

This allows the jack to be moved while the 'V-Lift' system (2) keeps the cylinder vertical.

⚠ CAUTION! Make sure that when the base plate is lowered to the floor and the handle is allowed to rise back up, your hands are clear of any pinch points above.

4. Make sure the cylinder saddle (5) is central to the lifting point before the lift is started.

⚠ WARNING! ALWAYS make sure the jack is positioned directly under the load and lifts vertically.

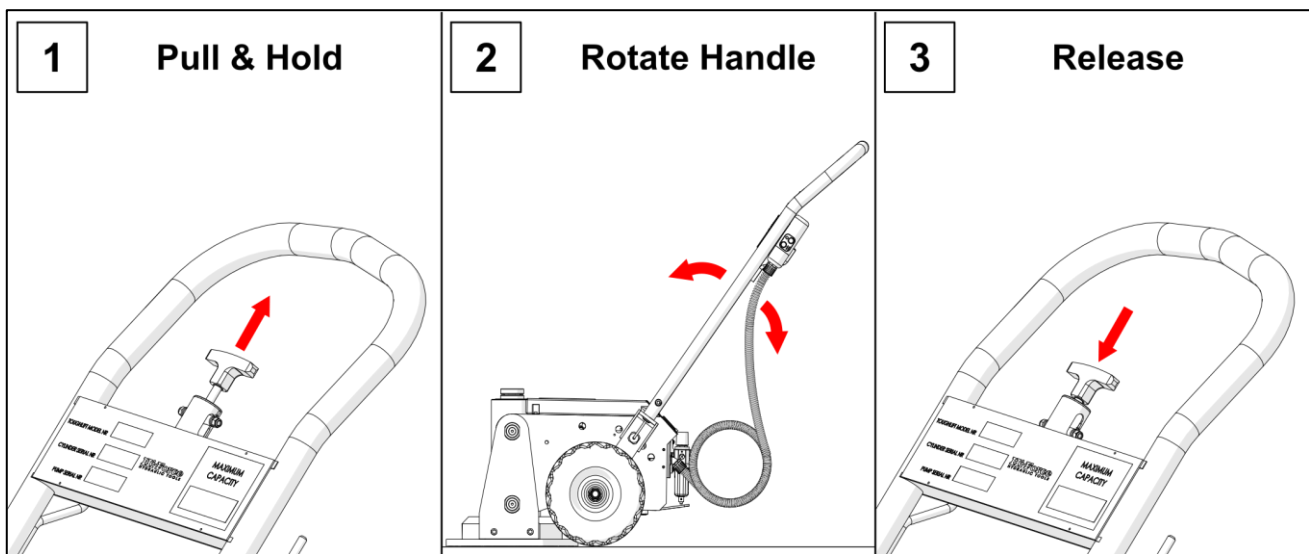

Figure 5.1: Handle Adjustment

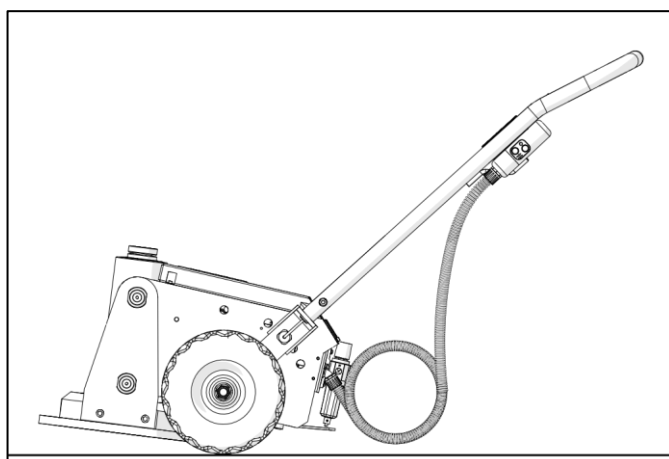

Figure 5.2: Moving the Unit

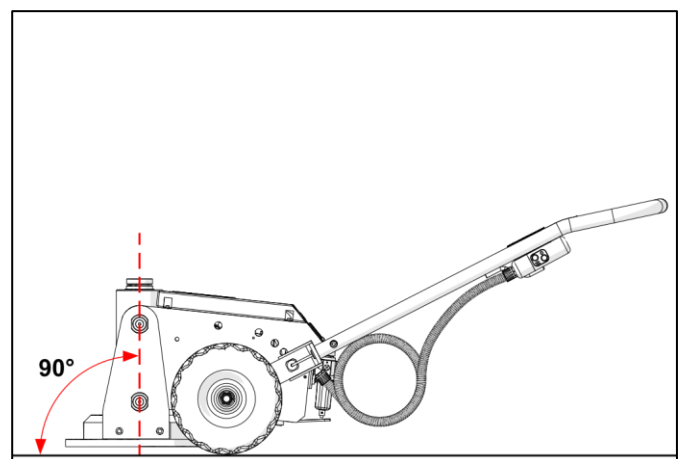

Figure 5.3: Accurate Positioning of the Unit

6.0 Operation

1. Connect the ToughLift to the air supply using an appropriate 3/8" BSP airline fitting.
2. Turn the air supply 'ON'. The air pressure supplied to the unit should ideally be between 6.2 bar (90 psi) and 7.0 bar (100 psi). Make sure that the supplied air pressure is not too high or too low. If necessary, adjust the air pressure using the air pressure regulator valve (24) located on the back of the jack.
3. Using the remote 'control pendant' (8), press the 'UP' button to extend/advance the jacking cylinder and the 'DOWN' button to retract the jacking cylinder. (See figure 6.1)
4. Advance the jacking cylinder to lift the load. Check constantly to make sure the load is stable and that the jack remains in a fixed and stable, 'vertical' position.
5. Fit load blocks as required and lower the load onto the load blocks (if used).
6. Retract the jacking cylinder to lower the load. Check constantly to make sure the load is stable and that the jack remains in a fixed and stable, 'vertical' position.
7. Turn the unit off by turning off the air supply source and disconnecting the air supply hose.

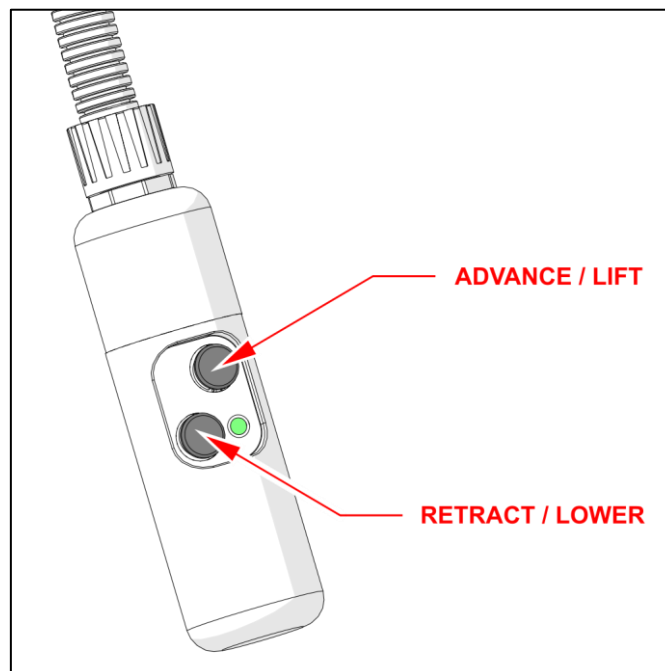

Figure 6.1: Control Pendant Operation

7.0 Lifting and Transport

7.1 Lifting the Toughlift

- Before lifting the unit, adjust the handle (See *figure 5.1*) into its forward most locked position (See *figure 7.1*). This places the handle directly over the units' centre of gravity, allowing it to be safely lifted by its handle.
- Attach the lifting strap to the uppermost horizontal beam of the handle assembly (See *figure 7.2*).

IMPORTANT: A lifting strap with a minimum capacity of 1 tonne and appropriately rated shackles fitted to each end, must be used.

- If necessary, attach guide wires to help control the movement of the unit during the lift.
- The ToughLift unit can now be safely lifted.

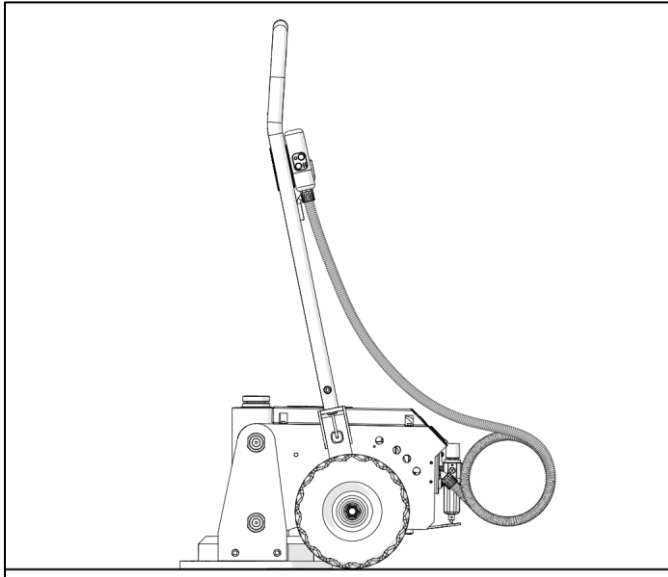

Figure 7.1: Handle Position for Lifting the Unit

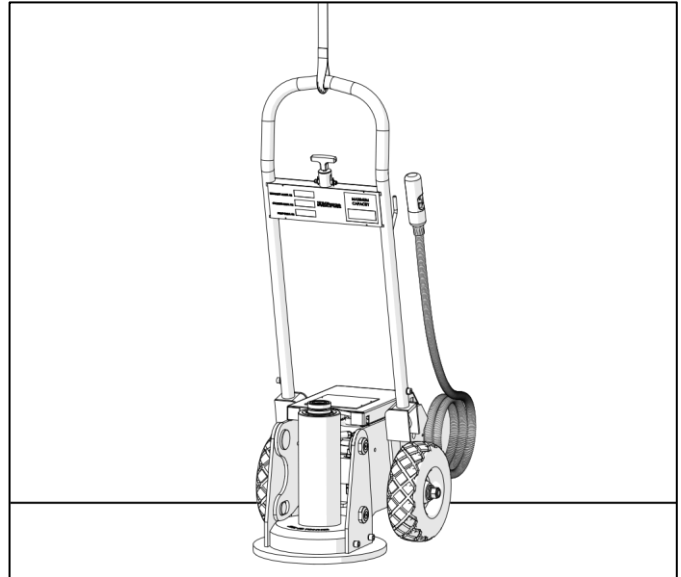

Figure 7.2: Lifting the Unit

7.2 Transporting the Toughlift

- Make sure the unit is securely fastened down and cannot shift during transport.

8.0 Maintenance and Storage

Carry out basic maintenance on a regular basis to keep the jacking system operating in a trouble-free manner. Maintenance intervals are determined by the frequency of use of the system and the operating conditions on site.

- Keep the unit clean. Particularly the saddle and load-lock/slip-lock extension pieces (if used).

All saddle receiver holes should be blown out, with compressed air. Then lightly lubricate the saddle pins and saddle receiver holes. Lubricate the handle positioning latch pins and holes (18).

- The oil level in the reservoir **should not** be allowed to drop below the centre of the upper oil level indicator sight-glass (16). (Cylinder fully retracted)

ALWAYS check the oil level with the lifting cylinder in the fully retracted position to ensure the correct oil level is displayed. Keep the oil reservoir topped-up with high grade ISO46 hydraulic oil as per section 5.3.

 **CAUTION!**

If the oil level does fall below the lower oil level indicator (at any time), air could be drawn into the pump, causing erratic operation and possible damage. To top up hydraulic oil, remove the top cover (13) and fill via the orange filler breather cap (9). (See Section 5.3)

Oil should be replaced after approximately 500 working hours, or more frequently in dusty conditions. To replace the oil, disconnect from the air supply, remove the oil drain plug (29) on the bottom of the reservoir and drain the used oil into a suitable container. Replace the oil drain plug (29) and refill with high grade ISO46 hydraulic oil as per section 5.3. Bleed trapped air from the system if necessary (See section 5.8).

IMPORTANT: **ALWAYS** dispose of used hydraulic oil in a responsible manner, in accordance with local regulations.

- Monitor the air systems' lubricator oil level (27). Maintain the level close to the maximum mark shown, using **ISO VG 32 (SAE10) Detergent Oil ONLY**. Adjust the oil delivery to between 1 & 2 drops per minute during the lifting cycle.

Top-up the air lubricating oil as required, via the air lubricator filler plug (25). See section 5.4.

 **CAUTION!** **DO NOT** use hydraulic oil in the air lubricator. Using the incorrect grade of airline oil may void your warranty.

9.0 Specifications

Refer to the nameplate on the unit for model identification.

TLA50 ToughLift Jacking System – Air Driven					
Model Number	Capacity (tonnes)	Power Supply	Stroke (mm)	Weight (kg)	Max Additional Stack (mm)
TLA5010	50	6-bar air driven	254	160	680
TLA5014	50	6-bar air driven	355	170	680

ToughLift TLA50 Systems use a 2-stage pump with the following pressure ranges and flow rates

Pump Stage	Pressure Range (bar)	Flow (l/min)
1	0 - 60	3.9
2	60 - 700	0.36

10.0 System Components/Accessories

(Refer to the Hi-Force website or latest Hi-Force catalogue, for further details)

- Range of Slip Lock Extensions (180mm – 500mm)
- Range of Load Lock Extensions (180mm – 500mm)
- Trolley Mounted Load Block Set

11.0 Troubleshooting

Hi-Force TLA50 ToughLift Jacking Systems should be serviced and repaired only by authorised Hi-Force repair centres. The following table gives possible causes and solutions for common problems.

TROUBLESHOOTING GUIDE		
Problem	Possible Cause	Solution
1. Air motor / Pump will not start.	a. Air supply not connected.	Connect air supply.
	b. Low air pressure / volume.	Check air supply, including regulator setting and the size of the connecting hoses to ensure the correct airflow / pressure requirements are met. (See section 5.5)
	c. Air supply hose restricted or damaged.	Check air supply hose for kinks, blockages or damage. Replace supply hose if damage is found.
	d. Air muffler frozen or clogged with ice.	Remove and clean the air muffler. Ensure the air supply is clean, dry and free of water. Check lubricator is filled to the required level.
	e. Air motor is damaged, seized or worn.	Contact your local Hi-Force office / distributor.
2. Air motor stalls or struggles to create pressure.	a. Low air pressure / volume.	Check air supply, including regulator setting and the size of the connecting hoses to ensure the correct airflow / pressure requirements are met. (See section 5.5)
	b. Inadequately lubricated air supply.	Check air lubricator levels and make sure the oil drip rate is correct. (See section 5.7)
3. Pump struggles to build pressure or maintain pressure under load.	a. Oil level too low	Check unit for visible leaks. Add oil as per section 5.3.
	b. External oil leak in the system.	Contact your local Hi-Force office / distributor.
4. Pump running hot.	a. Low oil level.	Add oil as per section 5.3.
	b. High-Pressure leakage at pump.	Contact your local Hi-Force office / distributor.
5. Cylinder will not advance.	a. Pump malfunction.	Contact your local Hi-Force office / distributor.
	b. Oil level too low.	Add oil as per section 5.3.
	c. Load too heavy for the cylinder.	Make sure the weight of the load to be lifted is within the rated capacity of the unit.
	d. Cylinder seals leaking.	Contact your local Hi-Force office / distributor.
	e. Faulty control pendant.	Contact your local Hi-Force office / distributor.

TROUBLESHOOTING GUIDE (continued...)

Problem	Possible Cause	Solution
6. Cylinder advances part way.	a. Oil level too low.	Add oil as per section 5.3.
	b. Cylinder piston binding.	Contact your local Hi-Force office / distributor.
	c. External obstruction.	Retract cylinder and clear obstruction.
7. Erratic cylinder movement.	a. Leakage from pump or valve internal components.	Contact your local Hi-Force office / distributor.
	b. Internal leak, due to damaged/worn seals or valves.	Contact your local Hi-Force office / distributor.
	c. Oil level too low.	Check unit for visible leaks. Add oil as per section 5.3.
	d. Air in the hydraulic system.	Bleed air from the system. (See section 5.8)
	e. Cylinder piston binding.	Contact your local Hi-Force office / distributor.
8. Cylinder stalls under load or before maximum tonnage is reached.	a. Control Valve damaged.	Contact your local Hi-Force office / distributor.
	b. Seal damage/wear or internal damage.	Contact your local Hi-Force office / distributor.
	c. Low air pressure/volume.	Check air supply, including regulator setting and the size of the connecting hoses to ensure the correct airflow / pressure requirements are met. (See section 5.5)
9. Cylinder advances, but will not hold.	a. Pump malfunction.	Contact your local Hi-Force office / distributor.
	b. Leaking connection.	Replace faulty component.
	c. Cylinder seals leaking.	Contact your local Hi-Force office / distributor.
10. Cylinder leaks oil.	a. Worn or damaged seals.	Contact your local Hi-Force office / distributor.
	b. Internal cylinder damage.	Contact your local Hi-Force office / distributor.
	c. Loose connection.	Tighten or repair the connection.
11. Cylinder will not retract or retracts slower than normal.	a. Faulty control pendant.	Contact your local Hi-Force office / distributor.
	b. Oil reservoir over-filled.	Drain excess oil from oil reservoir.
	c. Internal cylinder damage.	Contact your local Hi-Force office / distributor.
12. Overload protection valve (11) leaking.	a. Faulty Valve.	Contact your local Hi-Force office / distributor.
13. Noisy Operation	a. Air trapped in the hydraulic system.	Bleed air from the system. (See section 5.8)
	b. Air leaking into the hydraulic system.	Visually inspect all areas where air might leak into the hydraulic system.
	c. Oil level too low.	Check unit for visible leaks. Add oil as per section 5.3.

UK Head Office:

Hi-Force Limited
Prospect Way, Daventry, Northamptonshire
NN11 8PL
United Kingdom

Tel: + 44 1327 301000

Fax: + 44 1327 706555

Email: daventry@hi-force.com

Hi-Force Regional Offices:

Hi-Force Caspian

Baku

Azerbaijan

Tel: +994 124 474 100

Email: baku@hi-force.com

Hi-Force S.R.L.

Milano

Italy

Tel: +39 0257 607 174

Email: italy@hi-force.com

Hi-Force Hydraulics (Asia) S.B.

Selangor

Malaysia

Tel: +603 5525 4203

Email: malaysia@hi-force.com

Hi-Force Nederland B.V.

Numansdorp

Netherlands

Tel: +31 85 902 8111

Email: holland@hi-force.com

Hi-Force Saudi

Dammam

Saudi Arabia

Tel: +966 13 802 1338

Email: saudi@hi-force.com

Hi-Force Hydraulics

Abu Dhabi

United Arab Emirates

Tel: +9712 551 3100

Email: abu.dhabi@hi-force.com

Hi-Force FZE

Dubai

United Arab Emirates

Tel: +9714 8150 600

Email: dubai@hi-force.com

Hi-Force Jebel Ali

Dubai

United Arab Emirates

Tel: +9714 802 7400

Email: jebel.ali@hi-force.com