

TPA | AIR DRIVEN TORQUE WRENCH PUMPS - PREMIUM LINE



Working pressure 700 bar

High flow 3-stage pump unit

Compact and lightweight

- ▶ Low noise operation (<90 db)
- ▶ Supplied fitted with one set of quick connect couplers
- ▶ Exhaust air radiator cooling system fitted as standard
- ▶ Adjustable torque setting pressure relief valve with locking nut
- ▶ Remote hand pendant controller with 5 metres cable for easy operation
- ▶ Multi-outlet 4-way split block for simultaneous operation of up to 4 torque wrenches
- ▶ Factory fitted roll bar protection and carrying frame

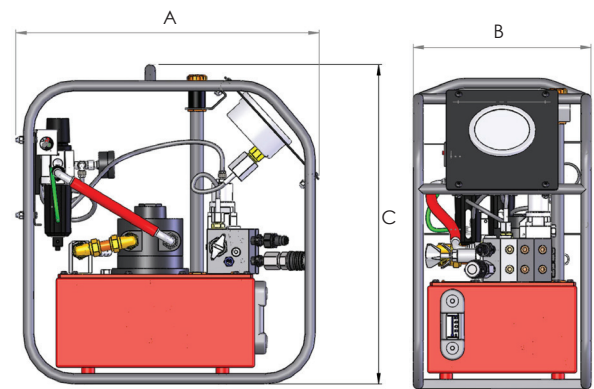

Model number	Power supply	Pressure gauge	Gauge reading	Flow rate (litres/minute)			Oil capacity (litres)	Max. oil temp (°C)	Weight incl. oil (kg)	Dimensions (mm)		
				1 st stage (0-65 bar)	2 nd stage (65-325 bar)	3 rd stage (325-700 bar)				A	B	C
TPA07A	7 bar air	analogue	bar/psi	7	1.6	0.8	7	80°	30	474	286	501

Optional coupler sets for simultaneous operation of multiple torque wrenches (one set supplied fitted as standard)

Model number	Description
TP-CS1	Single set of male/female flat face couplers, for simultaneous operation of two hydraulic wrenches
TP-CS2	Double set of male/female flat face couplers, for simultaneous operation of three hydraulic wrenches
TP-CS3	Triple set of male/female flat face couplers, for simultaneous operation of four hydraulic wrenches