

For permanent loads / longer distances

Roller Skate Express – The Super-Robusts

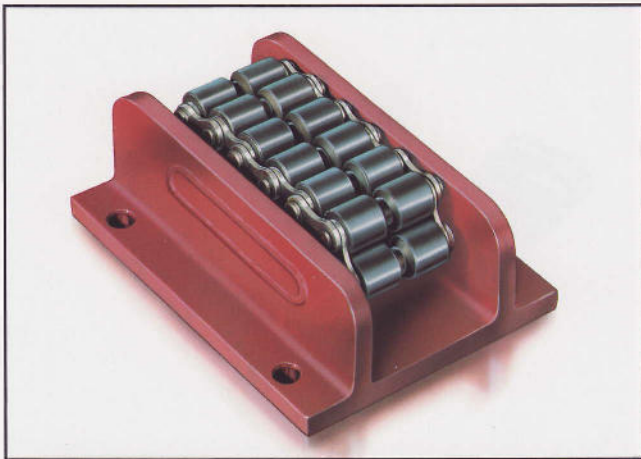

Hints on use:

- Check with the manufacturer before selection of Skates for use in a vertical position.
- Models I-IIIv have 4 bolt holes as standard.
- If problems of load distribution occur e.g. by wind forces, it is necessary to select model AM-H-50CrV4.
- Maximum speed: 5 m/min.
- The rolling resistance depends on the track. For smaller models I-IIIv 7-5 %, for larger models 5-3 % of the total load.
- Available with guide rollers (see drawing 11+12).
- Location of the fixing holes can be arranged to suit customers' requirements.
- Optional in galvanised or stainless steel construction.

Range of application:

- For longer distances and/or permanent loads.
- On suitable tracks, crane rails or steel beams.
- Movement of heavy loads for longer distances or for a long time e.g. for movements as a machine component, heavy duty telescope, guidance on component for very high radial force e.g. in ship building, in the machine engineering industry.
- Use as a conveyor, when the load is moving and the Roller Skates are fixed e.g. rolling table for heavy pallets of tube producer.
- Origin of concept: application in machine construction.

Characteristics of the series of model...AM:

- Extra robust construction.
- Low profile, exchangeable in outer dimensions with model...AS and ...A.
- More stability achieved, if load is firmly bolted to Roller Skates.
- More stable operation and distribution of load.
- Reduced wear by centre plate chain guide (no contact between chain and side walls, no wear to rivet heads).

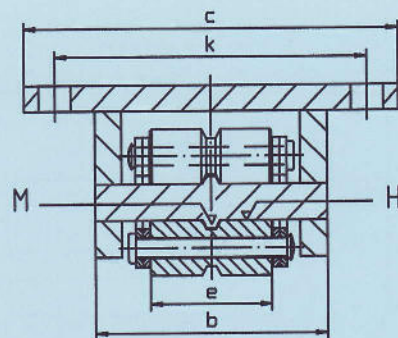
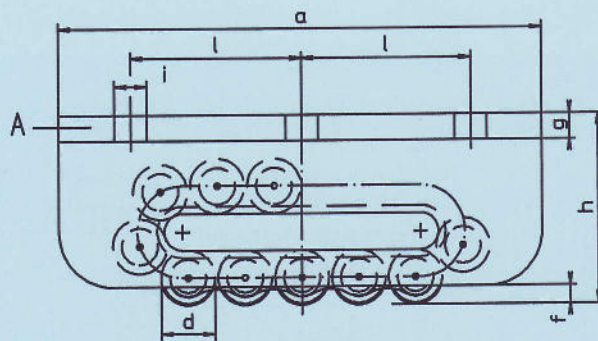

Mod. AM-H (H = hardened and machined centre plate), AM-H-50CrV4 (roller material 50CrV4)

Mod.	a	b	c	Ø d	e	f	g	h	Ø i	k	l	Rollers under stress	Number of Rollers	Maximum load kN	Weight kg
I	210	100	175	18	51	6	13	76	14	140	75	5	15	125	8.8
II	220	113	190	24	60	10	14	87	14	155	75	4	13	170	11.5
III	270	130	210	30	68	10	14	104	18	175	95	4	13	330	19.0
IIIv	320	140	220	30	68	10	18	115	18	180	120	6	17	420	28.5
IV	380	168	270	42	76	19	19	145	22	220	140	4	13	530	50.0
V	530	182	300	50	86	19	19	165	22	240	205	6	17	690	89.5
VL	580	182	300	50	86	19	23	170	26	250	250	8	21	880	104.0
Vv	650	205	350	50	100	20	28	190	26	280	240	9	23	1250	156.0
VI	900	205	380	50	100	20	38	200	33	300	360	13	31	1650	237.0

All dimensions in mm