

## Roller Skate Express – The Robusts

### Range of application:

- For short distances.
- If possible on suitable tracks, e.g. crane rails or steel beams.
- Movement of heavy loads in mining, steel industry, machine construction, bridge construction and other heavy industrial plants.
- Use as a conveyor, when the load is moving and the Roller Skates are fixed.
- Low level construction overcomes problems in confined space.

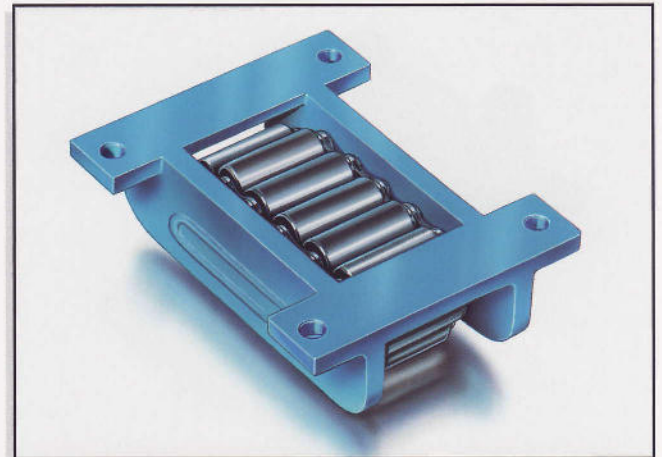

### Characteristics of the series of model...B:

- Stable, solid basic construction.
- Low level is achieved by recessing the mounting plates into side walls. Model... B and ... C are the same height.
- More stability by firmly bolting the Skates to the load.
- Available with hardened centre plate (= models B-H) or additionally with higher tensile roller material 50CrV4 (= SAE 6150) (= models B-H-50CrV4).

### Hints on use:

- If the Rollers are being used to their maximum carrying capacity or with lengthy intervals between use choose models with a hardened centre plate (= model B-H).
- In case of possible overload, choose chain roller material 50CrV4 (B.S. 735 A 50; SAE 6150) (= models B-H-50CrV4).
- Maximum speed: 5 m/min.
- The rolling resistance depends on the track. For smaller models I-III 7-5 %, for larger models 5-3 % of the total load.
- Can be arranged with guide rollers (see drawing 11+12).

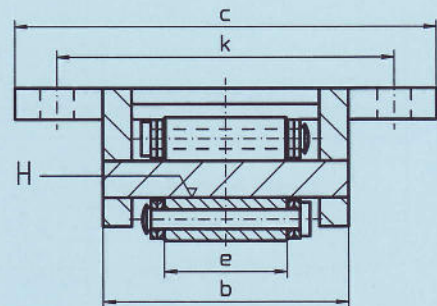
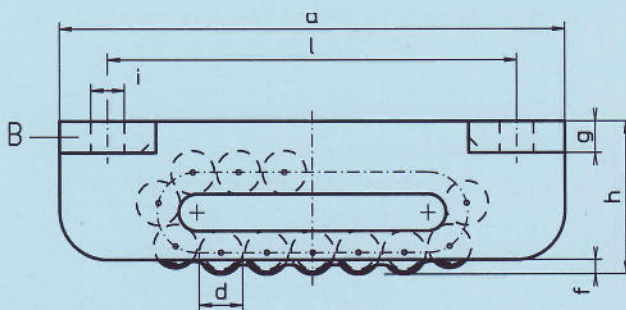

Mod. B, B-H (H = hardened and machined centre plate), B-H-50CrV4 (roller material 50CrV4)

Mod.	a	b	c	∅ d	e	f	g	h	∅ i	k	l	Rollers under stress	Number of Rollers	Maximum load kN	Weight kg
I	210	100	175	18	51	6	13	63	14	140	170	5	15	100	6.2
II	220	113	190	24	60	10	14	73	14	155	180	4	13	150	8.4
III	270	130	210	30	68	10	14	90	18	175	220	4	13	300	14.1
IV	380	168	270	42	76	19	19	126	22	220	320	4	13	600	36.5
V	530	182	300	50	86	19	19	146	22	240	470	6	17	800	66.4

All Dimensions in mm